



2017 SAE CLEAN SNOWMOBILE CHALLENGE ZERO EMISSIONS (ZE) RULES

TABLE OF CONTENTS

INTRODUCTION	4
ARTICLE 1: SAE CSC ZERO EMISSIONS CATEGORY OVERVIEW AND OBJECTIVE.....	5
1.1 Event Description	5
1.2 Competition Objective for Zero Emission Category	5
ARTICLE 2: SAE CSC RULES AND ORGANIZER AUTHORITY	5
2.1 Rules Authority.....	5
2.2 Rules Validity	6
2.3 Rules Compliance.....	6
2.4 Understanding the Rules.....	6
2.5 Participating in the Competition.....	6
2.6 Violations of Intent	7
2.7 Right to Impound.....	7
2.8 General Authority	7
2.9 SAE Technical Standards Access.....	7
ARTICLE 3: INDIVIDUAL PARTICIPATION REQUIREMENTS	7
3.1 Eligibility Limits.....	7
3.2 Student Status	7
3.3 University Collaboration	7
3.4 Age.....	8
3.5 Driver’s License.....	8
3.6 Medical Insurance.....	8
3.7 Liability Waiver.....	8
3.8 SAE Membership.....	8
3.9 Individual Registration Requirements for North American Competitions – ACTION REQUIRED	8
3.10 Online Registration Information is Required.....	8
3.11 On-site Registration Requirement	9
ARTICLE 4: FACULTY ADVISOR	9
4.1 Status	9
4.2 Responsibilities.....	9
4.3 Limitations.....	9
ARTICLE 5: REGISTRATION	9
5.1 Registration.....	9
5.2 Entries per University.....	9
5.3 Registration Limit – 25 vehicles.....	9
5.4 Registration Dates.....	10
5.5 Registration Fee.....	10
5.6 Team Member Affiliation.....	10
5.7 Withdrawals.....	10
5.8 United States Visas	10
5.9 Visa Requests	10
5.10 International Participation - Vehicle Shipping/US Customs	10
5.11 On-site Registration	11
ARTICLE 6: REQUIRED DOCUMENTATION, DEADLINES AND PENALTIES.....	11
6.1 Team Program Information	11
6.2 Electric Systems Form (ESF) Due on December 1, 2016	11



6.3	Design Paper and MSRP Due on February 20, 2017	11
6.4	Account Signup for Online Submission	12
ARTICLE 7: QUESTIONS & GENERAL INFORMATION		13
7.1	Official Communications.....	13
7.2	Question Submission	14
7.3	Question Publication.....	14
7.4	Loopholes and Problems.....	14
7.5	Engineering Ethics.....	14
7.6	Participants' Discussion.....	14
ARTICLE 8: SNOWMOBILE MODIFICATION		14
8.1	Baseline Snowmobile	14
8.2	Torque Controller Requirements	15
8.3	Drive	15
8.4	Skis and Ski Suspension	16
8.5	Track, Track Suspension, and Traction	16
8.6	Frame and Body.....	18
8.7	Ignition and Electrical.....	19
8.8	Component Deletion.....	20
8.9	Fire Extinguishers.....	20
ARTICLE 9: CONDUCT OF THE EVENT		21
9.1	Snowmobile Operating Requirements	21
9.2	Driver Protective Equipment	23
9.3	On Site Modifications (Bonus Points and Penalties).....	24
9.4	Permitted Maintenance Items	25
9.5	Drafting Prohibited	25
9.6	Unsportsmanlike Conduct	25
9.7	Drug and Alcohol Policy	25
9.8	Protests and Problems.....	26
9.9	Event Appearance and Forfeits.....	26
ARTICLE 10: SCORING.....		27
10.1	Overall Score	27
10.2	Event Points.....	27
10.3	Penalties.....	27
10.4	Engineering Design Paper	27
10.5	Manufacturer's Suggested Retail Price (MSRP)	28
10.6	Oral Design Presentation	31
10.7	Zero Emissions Range Test	31
10.8	Objective and Subjective Noise Events.....	32
10.9	Objective Handling & Drivability Event.....	32
10.10	Subjective Handling & Drivability Event.....	33
10.11	Acceleration Plus Load Event	34
10.12	Cold Start Event.....	34
10.13	Static Display Event/Networking with Industry	35
10.14	Snowmobile Weight	35
ARTICLE 11: AWARDS		36
11.1	Award Criteria	36
11.2	Participation Plaque	36
ARTICLE 12: ORGANIZER AUTHORITY		36
PART B: ELECTRICAL COMPONENT RULES		37
ARTICLE EV1 ELECTRIC SYSTEM DEFINITIONS		37

EV1.1	High-Voltage (HV) and Low-Voltage (LV).....	37
EV1.2	Grounded Low Voltage and Tractive System.....	37
ARTICLE EV 2 ELECTRIC POWERTRAIN.....		38
EV2.1	Motors	38
EV2.2	Accelerator Lever Position Sensor (ALPS).....	38
EV2.3	Brake System Encoder – BSE	39
EV2.4	ALPS Brake Pedal Plausibility Check.....	40
ARTICLE EV 3 TRACTIVE SYSTEM - ENERGY STORAGE.....		40
EV3.1	Allowed Tractive System Batteries	40
EV3.2	Tractive System Battery Container – General Requirements	40
EV3.3	Tractive System Battery Container - Electrical Configuration.....	40
EV3.4	Tractive System Battery Container - Mechanical Configuration.....	41
EV3.5	Battery Isolation Relay(s) (BIR).....	42
EV3.6	Battery Management System (BMS).....	43
EV3.7	Grounded Low Voltage System	44
ARTICLE EV 4 TRACTIVE SYSTEM – GENERAL REQUIREMENTS		44
EV4.1	Separation of Traction System and Grounded Low Voltage System	44
EV4.2	Positioning of tractive system parts	45
EV4.3	Tractive System Isolation	45
EV4.4	Grounding.....	46
EV4.5	Tractive System Measuring points (TSMP)	46
EV4.6	HV Insulation, wiring and conduit	47
EV4.7	Tractive System Enclosures.....	49
EV4.8	HV Disconnect (HVD)	49
EV4.9	Activating the Tractive System	49
EV4.10	Pre-Charge and Discharge Circuits	50
EV4.11	Vehicle Energized Light.....	50
EV4.12	Ready-To-Drive-Sound	50
ARTICLE EV 5 SHUTDOWN CIRCUIT AND SYSTEMS.....		51
EV5.1	Shutdown Circuit.....	51
EV5.2	Master Switches.....	53
EV5.3	Insulation Monitoring Device (IMD)	53
EV5.4 BRAKE SYSTEM PLAUSIBILITY DEVICE (BSPD).....		54
EV5.5	Charging Shutdown Circuit	54
ARTICLE EV 6 OVERCURRENT PROTECTION.....		55
EV6.1	Overcurrent Protection	55
ARTICLE EV 7 ELECTRICAL SYSTEM TESTS		55
EV7.1	Insulation Monitoring Device Test (IMDT).....	55
EV7.2	Insulation Measurement Test (IMT).....	56
EV7.3	Rain Test.....	56
EV7.4	Ready-To-Drive-Sound Test	57
ARTICLE EV 8 HIGH VOLTAGE PROCEDURES & TOOLS		57
EV8.1	Working on Tractive System Battery Containers	57
EV8.2	Charging	57
EV8.3	Battery Container Hand Cart	58
ARTICLE EV 9 ELECTRICAL SYSTEM FORM.....		58
EV11.1	Electrical System Form (ESF)	58
ARTICLE T11 ACRONYMS		59
APPENDIX A SNOWMOBILE DESCRIPTION FORM		60
APPENDIX B ENGINEERING DESIGN PAPER JUDGING FORM - ZERO EMISSIONS SLEDS		61
APPENDIX C ORAL PRESENTATION JUDGING FORM FOR ZE SLEDS		62
APPENDIX D HANDLING EVENT JUDGING FORM FOR ZE SLEDS		63
APPENDIX E INSPECTION FORMS FOR ZE SLEDS		64
APPENDIX F ELECTRICAL INSPECTION FORMS FOR ZE SLEDS		67
APPENDIX G SAE TECHNICAL STANDARDS		68



2017 SAE CLEAN SNOWMOBILE CHALLENGE ZERO EMISSIONS (ZE) RULES

INTRODUCTION

This introduction is intended to highlight some revisions to the 2017 SAE Clean Snowmobile Internal Combustion (IC) Challenge Rules that you may find of interest. Each year the CSC Rules Committee changes the rules to introduce a slightly different engineering challenge. This set of CSC Rules applies only to the IC categories including both spark ignited and diesel engine categories. A separate document has been written for the Zero Emissions (ZE) rules. Areas of commonality in the two categories are duplicated in each document.

These highlights touch on only part of the revised text and do not replace or change the Rules.

Caution - Neither this introduction, nor any other summary, is a substitute for reading and understanding the Rules. The Rules are a reference document and should be used for that purpose. Do not attempt to design your vehicle based on the parts of the Rules you happen to remember from the last time you read them or from previous year's rules. We cannot stress it too strongly – read the Rules thoroughly and repeatedly.

- 7.4 Loopholes and Problems
- 7.6 Participants Discussions
- 8.5.1 Track, Track Suspension and Traction
- 10.13.2 Static Display Scoring

Numerous EV sections have been updated. Please be sure to read the rules in their entirety.

- | | |
|------------------------------|----------------------|
| EV1.1.1 – EV1.1.3 | EV5.2.3 |
| EV1.2.4 | EV5.4 |
| EV1.27 and EV1.28 | EV5.5, 5.5.1 – 5.5.4 |
| EV2.2, 2.2.1, 2.2.3 – 2.2.12 | EV6.1, 6.1.1 – 6.1.8 |
| EV2.3, 2.3.1 – 2.3.6 | EV8.2.11 |
| EV2.4, 2.4.1 | |
| EV3.1.1 | |
| EV3.3.3 and EV3.3.4 | |
| EV3.3.9 | |
| EV3.6.3 | |
| EV3.6.5 | |
| EV3.6.7 | |
| EV3.7.3 | |
| EV4.1.4 | |
| EV4.1.9 | |
| EV4.6.1 | |
| EV4.6.5 | |
| EV4.6.13 | |
| EV4.8.1 | |
| EV4.10.6 | |
| EV4.11.2 | |
| EV5.1.2 | |
| EV5.1.4 and EV5.1.5 | |
| EV5.1.9 – EV5.1.11 | |



2017 SAE CLEAN SNOWMOBILE CHALLENGE ZERO EMISSIONS (ZE) RULES

ARTICLE 1: SAE CSC ZERO EMISSIONS CATEGORY OVERVIEW AND OBJECTIVE

1.1 Event Description

The SAE International Clean Snowmobile Challenge (CSC) is an engineering design competition for college and university student members of SAE International, organized and administered by SAE and Michigan Technological University. The modified snowmobiles will compete in a variety of events including emissions, noise, fuel economy/endurance, acceleration, handling, static display, cold start and design.

There are two categories in the SAE Clean Snowmobile Challenge, sleds driven by only one Internal Combustion (IC) engine and sleds drive by electrical power and thus have Zero Emissions (ZE). **No hybrid designs will be allowed to compete.**

1.2 Competition Objective for Zero Emission Category

The intent of the competition is to develop a snowmobile that could be used in areas of remote, research testing locations such as Summit Station in Greenland for the National Science Foundation (NSF) research. The Greenland Ice Cap acts like a sponge, absorbing atmospheric chemicals produced naturally, or via anthropogenic activities. Many of these chemicals are also photoactive in the lower troposphere and even in the upper layers of the snow. Research at Summit Station seeks to understand the processes involved and how they might play into the global cycling of these agents. Some of the chemical constituents under study are measured in parts per billion. Emissions resulting from the burning of fossil fuels on site can hopelessly skew the research results. Due to the sensitive nature of much of the research conducted at Summit Station, NSF seeks to find a “zero-emissions” vehicle for transporting researchers and support staff to and from research sites.

Electric snowmobiles or other forms of zero-emissions transportation have long been sought. Range and performance have always been extremely limiting factors that have precluded the successful development of commercially available models. Recent advancements in battery and motor technology have finally made it possible to realize vehicles with ranges adequate for some purposes. Zero-emissions personal transportation would allow the operation of more distant satellite camp facilities and allow access to areas previously accessible only by foot. In short, this is a tool that the research community needs now.

Snowmobiles in this category must be zero-emissions by default. Therefore, no test or points will be given for emissions. Instead, range and draw bar performance will be measured. Innovation will also be judged in this category.

ARTICLE 2: SAE CSC RULES AND ORGANIZER AUTHORITY

2.1 Rules Authority

The SAE Clean Snowmobile Challenge Rules are the responsibility of the SAE Clean Snowmobile Challenge Rules Committee and are issued under the authority of the SAE University Programs Committee. Official announcements from the SAE or the organizers shall be considered part of, and shall have the same validity as these rules.

Ambiguities or questions concerning the meaning or intent of these rules will be resolved by the SAE



Clean Snowmobile Challenge Rules Committee, SAE staff or by the individual competition organizers as appropriate.

2.2 Rules Validity

The SAE Clean Snowmobile Challenge Rules posted on the SAE website and dated for the calendar year of the competition are the rules in effect for the competition. Rule sets dated for other years are invalid.

2.3 Rules Compliance

By entering a SAE competition, the team, members of the team as individuals, faculty advisors, and other personnel of the entering university agree to comply with, and be bound by, these rules and all rule interpretations or procedures issued or announced by SAE, the SAE Clean Snowmobile Challenge Rules Committee, and the other organizing bodies.

All team members, faculty advisors and other university representatives are required to cooperate with, and follow all instructions from, competition organizers, officials, and judges.

Each team must appoint a team member to be the “Rules and Safety Officer (RSO)”.

The RSO must:

- Be present at the entire CSC event.
- Be responsible for understanding the CSC rules prior to the competition and ensuring that competing vehicles comply with all CSC rules requirements.
- System Documentation – Have vehicle designs, plans, schematics and supporting documents available for review by the officials as needed.
- Component Documentation – Have manufacturer’s documentation and information available on all components of the electrical system.
- Be responsible for team safety while at the event.
 - This includes issues such as:
 - Use of safety glasses and other safety equipment.
 - Control of shock hazards such as charging equipment and accessible high voltage sources.
 - Control of fire hazards such as fuel, sources of ignition (grinding, welding etc.).
 - Safe working practices (lock-out/tag out, clean work area, use of jack stands etc.)
 - Be the point of contact between the team and FH organizers should rules or safety issues arise.
- Preferably, this will be the team's faculty advisor or a member of the university's professional staff, but the position may be held by a student member of the team.
- Contact information for the RSO (Name, Cell Phone number, etc.) must be provided to the organizers at registration.

2.4 Understanding the Rules

Teams are responsible for reading and understanding the rules in effect for the competition in which they are participating. The section and paragraph headings in these rules are provided only to facilitate reading; they do not affect the paragraph contents.

2.5 Participating in the Competition

Teams, team members as individuals, faculty advisors and other representatives of a registered university who are present on-site at a competition are considered to be “participating in the competition” from the time they arrive on-site until they depart at the conclusion of the competition or earlier by withdrawing.



2.6 Violations of Intent

The violation of the intent of a rule will be considered a violation of the rule itself. Questions about the intent of a rule may be addressed to the Clean Snowmobile Challenge Rules Committee or by the individual competition organizers as appropriate.

2.7 Right to Impound

SAE and other competition organizing bodies reserve the right to impound any onsite registered vehicles at any time during a competition for inspection and examination by the organizers, officials and technical inspectors.

2.8 General Authority

SAE and the competition organizing bodies reserve the right to revise the schedule of any competition and/or interpret or modify the competition rules at any time and in any manner that is, in their sole judgement, required for the efficient operation of the event.

2.9 SAE Technical Standards Access

A cooperative program of SAE's Education Board and Technical Standards Board is making some of SAE's Technical Standards available to teams registered for any North American Collegiate Design Series competition at no cost. The Technical Standards referenced in the Collegiate Design Series rules, along with other standards with reference value, will be accessible online to registered teams, team members and faculty advisors. To access the standards (1) your team must be registered for a competition in North America and (2) the individual team member or faculty advisor wanting access must be linked to the team in SAE's system.

Access Procedure - Once your team has registered there will be a link to the technical standards titled "Design Standards" on the main registration screen where all the required on-site registration information is added. On the technical standards webpage, you will have the ability to search standards either by J-number assigned or topic of interest such as brake light.

A list of the accessible SAE Technical Standards can be found in Appendix G.

ARTICLE 3: INDIVIDUAL PARTICIPATION REQUIREMENTS

3.1 Eligibility Limits

Eligibility is limited to undergraduate and graduate students to ensure that this is an engineering design competition. High school students are prohibited.

3.2 Student Status

Team members must be enrolled as degree seeking undergraduate or graduate students in a college or university. Team members who have graduated during the seven (7) month period prior to the competition remain eligible to participate.

Undergraduate participation is strongly encouraged. Graduate student participation is allowed, but limited to no more than 25% of the undergraduate participation on any individual team.

3.3 University Collaboration

Collaboration between schools will be accepted if both schools meet all requirements stated in the rules.

Teams which are formed with members from two or more Universities are treated as a single team. A student at any University making up the team may compete at any event where the team participates.



The multiple Universities are in effect treated as one University and all eligibility requirements (one car per competition class, one registration slot, etc.) are enforced.

3.4 Age

Team members must be at least eighteen (18) years of age.

3.5 Driver's License

Team members who will drive a competition vehicle at any time during a competition must hold a valid, government issued driver's license.

3.6 Medical Insurance

Individual medical insurance coverage is required and is the sole responsibility of the participant.

3.7 Liability Waiver

All on-site participants, including students, faculty, team spectators, and volunteers, are required to sign a liability waiver upon registering on-site.

3.8 SAE Membership

Team members must be members of SAE. Proof of SAE membership is required at the event.

Information on SAE Student membership can be found on SAE's website:

www.sae.org/students

3.9 Individual Registration Requirements for North American Competitions – ACTION REQUIRED

3.9.1 All students and faculty, both domestic and international, if you have an SAE International membership, make sure you are affiliated to your respective school/ college/ university on the SAE website under your "MySAE".

3.9.2 If you are not a member of SAE International or other approved societies, you will need to join SAE International online at www.sae.org. Select the "Join /Renew/Upgrade" link under the Membership tab, and then select "Professional or Student". Students will need to select the "Student Membership" link and then follow the series of the questions that are asked. Faculty that wishes to be SAE members should choose the "Professional Membership" link and proceed to the series of questions. Please note all student participants must be SAE International members to participate in the event. It is not mandatory for faculty to join.

3.9.3 All international student participants (or unaffiliated faculty advisors) who are not SAE International members are required to create a free customer account profile on www.sae.org. Upon completion, please email CollegiateCompetitions@sae.org their assigned customer number also stating which event and university name.

3.10 Online Registration Information is Required

Every participant, including advisors must affiliate themselves and complete the following information on under the team's registration page on the SAE website www.sae.org:

- Emergency contact data (point of contact (parent/guardian, spouse), relationship, and phone number)

To do this you will need to go to "Registration" page under the specific event the team is registered and then click on the "Register Your Team / Update Team Information" link. At this point, if you are properly affiliated to the school/college/university, a link will appear with your team name to select. Once you have selected the link, the registration page will appear. Selecting the "Add New Member" button will allow individuals to include themselves with the rest of the team. This can also be completed



by team captain and faculty advisor for all team members.

All students, both domestic and international, must affiliate themselves online by January 31 of the year of the competition. For additional assistance, please contact CollegiateCompetitions@sae.org.

3.11 On-site Registration Requirement

ON-SITE REGISTRATON IS REQUIRED OF ALL TEAM MEMBERS AND FACULTY ADVISORS.

Bring your (1) Government issued driver's license or passport and (2) your medical insurance card or documentation to onsite registration.

ARTICLE 4: FACULTY ADVISOR

4.1 Status

Each team is expected to have a Faculty Advisor appointed by the respective university. The Faculty Advisor is expected to accompany the team to the competition and will be considered by competition officials to be the official university representative.

4.2 Responsibilities

Faculty Advisors may advise their teams on general engineering and engineering project management theory.

4.3 Limitations

The faculty advisor may not design any part of the vehicle nor directly participate in the development of any documentation or presentation. Additionally, Faculty Advisors may neither fabricate nor assemble any components nor assist in the preparation, maintenance, testing or operation of the vehicle.

In short: Faculty advisor may not design, build or maintain the vehicle.

ARTICLE 5: REGISTRATION

5.1 Registration

Registration for SAE Clean Snowmobile Challenge must be completed online. Teams are required to select which class they will be participating in. Online registration must be done by either (a) an SAE member or (b) the official faculty advisor connected with the registering university and recorded as such in the SAE record system.

NOTE: It typically takes at least 1 working day between the time you complete an on-line SAE membership application and our system recognizes you as eligible to register your team.

5.2 Entries per University

Registration for the SAE Clean Snowmobile Challenge is limited to one vehicle per university in reach of the three categories: Internal Combustion – ignition spark, Diesel Utility Class and Zero Emissions.

5.3 Registration Limit – 25 vehicles

Registration for the SAE Clean Snowmobile Challenge is limited to 25 snowmobiles.



5.4 Registration Dates

Registration for the competition will open at the date and time posted on the competition website.

Registration for the competition will close at the date and time posted on the competition website.

There are no exceptions to this registration policy.

5.5 Registration Fee

Payment for registration fee must be initiated within 48 business hours of team registration.

Registration fees are NOT refundable, nor deferrable to future competitions.

5.6 Team Member Affiliation

See Rule 3.9

5.7 Withdrawals

Registered teams for the competition that find that they will not be able to attend the competition are required to officially withdraw notifying CDS Staff at collegiatecompetitions@sae.org prior to the competition.

5.8 United States Visas

Teams requiring visas to enter to the United States are advised to apply at least sixty (60) days prior to the competition. Although most visa applications seem to go through without an unreasonable delay, occasionally teams have had difficulties and in several instances visas were not issued before the competition.

Don't wait – apply early for your visa.

Neither SAE staff nor any competition organizers are permitted to give advice on visas, customs regulations or vehicle shipping regulations concerning the United States or any other country.

5.9 Visa Requests

Affiliated CDS Student Team Members will have the ability to print out a Registration Confirmation Letter for the individual event(s) that they are attending. Once a student team member affiliated themselves to their team's profile page under their individual edit section. They will have the opportunity to print out their personalized letter with the following information: Student's Name, School's Name, the CDS Event Name, Official Dates and Location(s).

Please be advised that SAE International cannot intervene with by calling or sending personal letters to the State Departments, Embassies or Consulates of the United States or other governments on behalf of any meeting or event participant.

5.10 International Participation - Vehicle Shipping/US Customs

- 5.10.1 SAE and the organizers strongly recommend that international teams ship their vehicle(s) early to allow enough time to compensate for any delays that may occur in clearing U.S. Customs. Please check with the United States Customs Service concerning the regulations governing the temporary importation of vehicles. You may want to consider using the services of a freight forwarder who is familiar with the international shipping of vehicles.

SAE staff and competition organizers are not permitted to provide advice on U.S. Custom matters.

5.10.2 Vehicle shipments by commercial carrier must comply with the laws and regulations of the nations from which, and to which, the snowmobile is being sent. Teams are advised to consult with their shipping company or freight forwarder to be sure that their shipment fully complies with all relevant customs, import/export and aviation shipping requirements.

5.11 On-site Registration

All team members and faculty advisors must complete the on-site registration procedures immediately after they arrive at the competition site.

On-site registration must be completed and any credentials and/or other identification issued by the organizers properly worn before the car can be unloaded, uncrated or worked upon in any manner.

ARTICLE 6: REQUIRED DOCUMENTATION, DEADLINES AND PENALTIES

6.1 Team Program Information

Teams must submit the mandatory required information below after completing the registration process. If no team information is provided by the deadline, a picture from CSC archives will be used in the event program. If no picture exists, the team will not be included.

- a) Complete Team Program Information Form and submit
- b) Submit Team Photo

The photograph will be printed in the program on a page measuring 5.5 by 8.5 inches. The photograph will typically be 4 to 4.5 inches wide by 2 or 3 inches tall. The required resolution is 300 pixels per inch when printed on paper. If no photo is provided the organizers will decide what will be on the team page.

NOTE: Pictures that look good on computer screens look different on paper. When in doubt, use the highest resolution the camera or scanner will allow.

The information must be uploaded at time of registration to <http://saecleansnowmobile.com/>.

6.2 Electric Systems Form (ESF) Due on December 1, 2016

The ESF must be uploaded to the <http://saecleansnowmobile.com/> website. The date/time of upload online constitutes the official record for deadline compliance.

The paper must be received no later than 11:59 p.m. EST on December 1, 2016.

Reference CSC ZE Rules Part B: Rule EV9.1 for description.

NOTE: Late ESF submissions will accrue ten (10) penalty points for each day that they are late, up to a maximum penalty equal to the team's score for this event. This includes delivery of the large font document. Confirmation of successful submission is indicated by the submission box turning green.

6.3 Design Paper and MSRP Due on February 20, 2017

The final Engineering Design Paper, describing the modifications made to the snowmobile, and the final MSRP are due on February 20, 2017.

6.3.1 Engineering Design Paper

Teams must submit two (2) copies of their paper; one (1) copy in normal font following SAE Paper template and one (1) copy in large font 16 point. Failure to submit both files will result in an incomplete submission. The reports must be uploaded to <http://saecleansnowmobile.com/>.

The paper must be uploaded no later than 11:59 pm EST on February 20, 2017.

NOTE: Late engineering design papers will accrue ten (10) penalty points for each day that they are late, up to a maximum penalty equal to the team's score for this event. This includes delivery of the large font document. Confirmation of successful submission is indicated by the submission box turning green.

6.3.1.1 File Format for Engineering Design Paper

Both copies of the Engineering Design Paper must be submitted in Adobe Acrobat PDF file format. No other file type will be accepted.

6.3.1.2 Naming Convention for Engineering Design Paper

Teams must include their team number and name of their University in the PDF file name. For example, "01_UW-Madison_Design_Paper.pdf" and "01_UW-Madison_Design_Paper_Large_Format.pdf".

NOTE: Be sure when uploading files online you submit to correct submission areas.

6.3.2 Manufacturer's Suggestion Retail Price

Once (1) electronic copy of the Manufacturer's Suggested Retail Price Assessment (MSRP) is due. A copy of all supporting documentation should be brought to the competition. The MSRP judges will ask to see supporting documentation for the MSRP during the competition in a 20-minute presentation and explanation of the MSRP. The reports must be uploaded to <http://saecleansnowmobile.com/>.

The MSRP must be uploaded no later than 11:59 pm EST on February 20, 2017.

NOTE: Late MSRP submissions will accrue ten (10) penalty points for each day that they are late, up to a maximum penalty equal to the team's score for this event. Confirmation of successful submission is indicated by the submission box turning green.

NOTE: All teams will be required to update their MSRP at the start of the competition and have their snowmobile inspected to verify that their MSRP is complete and accurate. Teams not submitting a complete and accurate MSRP will be ineligible to receive the awards for Most Practical Solution and Best Value.

6.3.2.1 File Format for Manufacturer's Suggested Retail Price

The Manufacturer's Suggested Retail Price document must be presented in Microsoft Office Excel 2007 format (.xlsx).

6.3.2.2 Naming Convention for Manufacturer's Suggested Retail Price

Teams must include their team number and the name of their university in the Microsoft Office Excel 2007 file name. For example, "01_UW-Madison_MSRR.xlsx".

6.4 Account Signup for Online Submission

Account creation for online document submission requires the following steps:

- a. Visit <http://saecleansnowmobile.com/>
- b. Follow the account signup instructions on the website. Select "Your Affiliation" as either "Team Captain/Team Advisor" or "Team Member (non-captain)"
- c. Your "authentication number" for online signup is the SAE confirmation number that was issued when your team registered.

NOTE - There may be a delay of up to three (3) business days between the time your team registers



for a competition and the saecleansnowmobile.com site recognizes the validity of your authentication number and the team captain may create an account.

Once your team captain has created an account it will remain valid until your team becomes dormant or no longer registers to compete.

d. Responsibilities and Restrictions

Team Captain Role – Each team must have at least one person identified online as the Team Captain. The Team Captain(s) has unique responsibilities on the site including accepting other team members for site access. Until the captain accepts a member’s signup that person cannot upload or view team documents. Team captains automatically have the same roles and privileges as their team members.

Team Member Restrictions – Team members must be approved by the Team Captain or the Faculty Advisor before being able to view or upload team documents.

Uploading Documents – All team members and the team captain have equal authority to upload and/or replace documents in the name of the team.

Document Access – Uploaded documents can only be viewed by (1) members of the submitting team, (2) authorized judges, technical inspectors and officials and (3) CDS staff.

Reminder – The website does not know what you intended to submit or what you thought you were doing. Anything your team uploads to the site is considered to be an official action by your team.

NOTE – Not all team members need to be affiliated on the saecleansnowmobile.com website; however, team members responsible for submitting documents by the deadlines must be added.

Transfer of Team Captain Responsibility – Important – If your captain is leaving the team, through graduation or otherwise, it is important that the departing captain “pass the baton” by designating one, or more, new captains on the saecleansnowmobile.com website. Only your team captain(s) has the authority to add team members and new/additional captains.

Please note that your team can designate more than one captain. But before you do so, remember that all your captains will have equivalent authority on the saecleansnowmobile.com website.

SAE.org Website Actions	saecleansnowmobile.com Website Actions
<ol style="list-style-type: none"> 1. Complete Program Submission 2. Update Team Website & Social Media 3. Pay Your Team Invoice 4. Affiliate all members through Team Profile 5. Reprint your Team Invoice 6. Print Registration Confirmation Letter 7. Print Participation Certificate 8. Print Fast Track Roster 	<ol style="list-style-type: none"> 1. Affiliate those Submitting Documents 2. Affiliate those Asking Rules Questions 3. Ask Rules Questions 4. Submit Required Documents

ARTICLE 7: QUESTIONS & GENERAL INFORMATION

7.1 Official Communications

Teams are required to read the published announcements by SAE and the other organizing bodies and to be familiar with all official announcements concerning the competitions and rules interpretations



released by the SAE Clean Snowmobile Challenge Rules Committee.

Miscellaneous information on competition logistics and administration will be posted online any of the four forms of media below.

7.1.1 SAE Clean Snowmobile Challenge News

- News will be provided to students in all four forms of media:
- Emails to registered student members online www.sae.org
- Press releases published online at <http://students.sae.org/cds/snowmobile/news/>
- Rules updates published online at <http://saecleansnowmobile.com/>
- Challenge Public Discussion Forum on the SAE Website <http://forums.saecleansnowmobile.com/>.

7.2 Question Submission

Rules Questions are to be submitted online www.saecleansnowmobile.com.

7.3 Question Publication

By submitting a question to the SAE Clean Snowmobile Challenge Committee or the competition's organizer you and your team agree that both your question and the official answer can be reproduced and distributed by SAE, in both complete and edited versions, in any medium or format anywhere in the world.

7.4 Loopholes and Problems

Any perceived loopholes in or potential problems with the rules should be provided to organizers via the designated folder in the SAE Clean Snowmobile Challenge Public Discussion Forum on the SAE Website <http://forums.saecleansnowmobile.com/>. Suggestions for rule changes must reference the appropriate SAE CSC rule number, state the current wording of the rule, and contain a suggestion of how the rule should be changed.

7.5 Engineering Ethics

The SAE Clean Snowmobile Challenge is an engineering design competition that requires performance demonstration of snowmobiles. It is NOT a race. Engineering ethics will apply. In all events violation of the intent of the rule will be considered a violation of the rule.

7.6 Participants' Discussion

A Participants' Discussion folder has been provided in the SAE Clean Snowmobile Challenge Public Discussion Forum on the SAE Website <http://forums.saecleansnowmobile.com/>. Participants are encouraged to use this folder to ask questions of and share information with other teams.

ARTICLE 8: SNOWMOBILE MODIFICATION

8.1 Baseline Snowmobile

Teams are expected to provide their own snowmobile for modification. The baseline snowmobile must be a stock qualified snowmobile, defined as a model that was produced in a quantity of at least 300 units. **The model year of the base snowmobile must be from the model years 2013 to 2017 inclusive from one of the four major snowmobile manufacturers (Arctic Cat, BRP (Ski Doo), Polaris, or Yamaha).**

The intent of the competition is for student teams to modify an existing snowmobile to improve emissions and noise characteristics. Teams choosing to ignore this intent by entering a snowmobile made clean and quiet by a manufacturer or aftermarket supplier will be disqualified. Competition

organizers will be responsible for making this subjective determination, if necessary.

8.2 Torque Controller Requirements

The thumb actuated torque controller must remain on the right side of the handlebar consistent with modern snowmobiles. An adequate return spring is required. Drive-by-wire systems are allowed.

8.3 Drive

8.3.1 Transmission

The requirement for a variable ratio belt transmission will be waived for electric drive designs.

8.3.2 Brake Performance Requirement

All brake modifications are subject to retaining the braking performance of the original snowmobile. This will be tested during the technical inspection before snowmobiles are allowed to compete in the competition.

The master cylinder, caliper and rotor assembly must be commercially available.

The "commercially available" stipulation can be accomplished two ways. Other brake systems, for example motorcycle, small tractors, and other off-road vehicles may use smaller diameter brakes. The concern is mainly one of material specifications for the parts. Commercially available systems will most likely satisfy some quality standard for the caliper and rotor assembly regarding the durability of the parts.

The second way is to reduce the rotor diameter of a commercially available system. At least then you have started with parts that again satisfy some material standard. In stopping snowmobiles, usually the brakes lock up and the snowmobile slides on the snow, so there is plenty of clamping force available. A fifteen percent (15%) reduction in surface area will probably not change this.

Brake rotor on drive axle track shaft must be at least seven (7) inches minimum diameter. If the secondary brake is on the track shaft, the rotor may be smaller than seven (7) inches. Additional brake assemblies may be added. Axle shaft may be lengthened to accommodate additional brakes.

Moving the brake to the track drive axle is allowed. The brake components must be commercially available and the pad contact area cannot be reduced by more than fifteen percent (15%).

Replacement brake rotor of aluminum or carbon fiber is not allowed.

8.3.3 Brake Control Handle

The brake control handle must remain in the OEM location (front left side). Brakes must be operative at all times.

8.3.4 Brake Rotor Shield

If the brake system is standard as supplied by the manufacturer, no additional brake rotor shield is required. If the brake system is modified, the brake rotor must be covered with a shield capable of retaining an accidental explosion.

8.3.5 Rotor Contact Area

The rotor pad contact surface area may not be reduced more than fifteen percent (15%) of the original pad contact surface area.

8.3.6 Moving Parts Isolation

Chains, pulleys, and exposed moving parts will be isolated from the driver and other competitors by shields capable of retaining all accidental explosions and component impacts. No holes may be drilled in protective shields.

8.3.7 Moving Parts Isolation

Except for the Belt Guard and Clutch Cover mentioned in 4.4.7, chains, pulleys, and exposed moving parts will be isolated from the driver and other competitors by shields capable of retaining all accidental explosions and component impacts.

8.4 Skis and Ski Suspension

8.4.1 Ski Requirements

Skis must be commercially available.

8.4.2 Ski and Ski Suspension Modification

The snowmobile's skis and ski suspension may be modified. However, the snowmobile must remain ski-steered.

8.4.3 Ski Runners

Carbide ski runners are allowed.

8.4.4 Ski Suspension Requirements

The following measurement procedure will be used to verify ski suspension travel:

With the driver in the seated position, a measuring stick will be placed at the front bumper of the snowmobile. This point on the measuring stick will be noted as "Point A."

With the driver still on the snowmobile, weight will be added to the snowmobile until the ski suspension is fully compressed. This point will be noted on the measuring stick as "Point B."

The ski suspension travel is the distance from "Point A" to "Point B." The ski suspension travel must be equal to or greater than three (3) inches.

Adjustments to the ski suspension (spring and damping) are allowed, provided the minimum ski suspension travel of 3 inches is maintained. There will be no loss of the 100 point "No Maintenance Rule" for ski suspension adjustments.

8.5 Track, Track Suspension, and Traction

8.5.1 Track and Track Suspension Modification

The snowmobile's track may be replaced with a different track. The track must be a commercially available, one piece, molded rubber snowmobile track. The selected, commercially available track may not be modified except for traction studs. The same track design must be used for all events. Commercially available pre-studded tracks from Camso are allowed. If used, Rule 8.5.3 does not apply. Tracks specially modified by Camso will be allowed provided the part number and serial number from Camso are provided for verification at the competition. Tracks modified by any other individual or company will not be allowed.

8.5.2 Track Suspension Requirements

The following measurement procedure will be used to verify track suspension travel:

With the driver in the seated position, a measuring stick will be placed at the rear bumper of the

snowmobile. This point on the measuring stick will be noted as "Point C."

With the driver still on the snowmobile, weight will be added to the snowmobile until the track suspension is fully compressed. This point will be noted on the measuring stick as "Point D."

The track suspension travel is the distance from "Point C" to "Point D." The track suspension travel must be equal to or greater than three (3) inches.

Adjustments to the track suspension (spring and damping) are allowed, provided the minimum track suspension travel of 3 inches is maintained. There will be no loss of the 100 point "No Maintenance Rule" for track suspension adjustments.

8.5.3 Traction Control Devices

The use of traction control devices such as ice grousers, grass hooks, or paddles is not allowed.

The use of track studs is allowed.

Regardless of track length or width, the snowmobile is limited to two (2) commercially available studs per bar, 60 degree unsharpened, unmodified single point studs (see example picture below).



All components of the traction devices must be located in the center of the track between the inside edges of the two slide runners and a minimum of 3.75 inches from the edge of the track.

The stud may not protrude more than .375 inch above the highest point on the track.

Stud backing plate maximum size is 2 inches x 2.25 inches.

Backing plates may not extend beyond the height of the rib and must rest against the rib. Sharpening (vertically or horizontally) of the backing plate is not allowed.

8.5.4 International Engineering, Inc. (Woody's) is the official supplier for traction studs for CSC and they are available for technical assistance in track stud installation. Teams choosing to use track studs must contact Woody's prior to the Challenge to ensure proper track stud selection and installation. The contact at Woody's is Mark Musselman mark@wiem.com (989) 689-4911 ext. 108

8.5.5 Slide Runner

Slide runners may be drilled. OEM type slide runners may be used as a replacement. Inserts may be added to the slide runner. The slide rail lubrication system (ice scratchers) will be allowed this year. Only ice scratchers that do not have to be stowed when in reverse like the Slidekick design will be allowed.

8.5.6 Maximum Track Lug Height

The maximum height of track lugs is two (2) inches.

8.6 Frame and Body

8.6.1 Rear Snow Flap

A Rear snow flap is required.

If a team's base sled is a "touring" sled designed to travel on groomed snowmobile trails, then the stock rear snow flap as provided by the manufacturer is acceptable. Off road or "mountain" sleds typically have rear snow flaps designed for that purpose and are much higher off the ground and are not acceptable. The rear snow flap design could affect the noise of the snowmobile. For this reason, we encourage innovation in this area. Here are some guidelines to follow should your team decide to design your own rear snow flap.

- 1) Be securely fastened to the tunnel or chassis (a snow flap that falls off or is inadequately held on to the snowmobile during competition will incur penalties for safety and repair).
- 2) Be wider than the track of the snowmobile. Tapered or shaped snow flaps are allowable provided that the narrowest point is wider than the track.
- 3) Be in close proximity (one inch or less) to the ground when the lightest operator is on the machine.
- 4) Be adequately rigid (or massive) to remain in close proximity with the ground during high-speed operation.
- 5) Be adequately supported so that the flap does not get drawn into the track during reverse maneuvers (if so equipped).

Snow flaps in question will be dynamically tested. Snow flaps that are deemed to not meet the above criteria will not be allowed.

Snow flaps from prior year competition do not necessarily meet the above requirements and are not "grandfathered in".

8.6.2 Foot Stirrups/Pegs

Foot stirrups/foot pegs constructed of rigid materials may be installed.

8.6.3 Seat

All sleds will be equipped with an upholstered, padded seat with a minimum thickness of one (1) inch, a length of twenty-four (24) inches, and a width of the tunnel.

8.6.4 Body Modification

The snowmobile body may be modified. The hood must have top and side cowling and must contain at least one thousand three (1300) square inches.

8.6.5 Front Bumper Requirement

All snowmobiles must have a front bumper strong enough to support the snowmobile while suspended in mid-air (for ease of lifting).

8.6.6 Decal Space Requirement

Two hundred (200) square inches of space must be left free on the hood/tunnel of the snowmobile for sponsorship decals to be placed upon arrival to the competition.

8.6.7 Team Number

The team number must appear in at least four (4) places on the snowmobile: Both sides of the hood and both sides of the tunnel. (A) The numbers on the hood sides must be six (6) inches high, ¾ inches wide. (B) The numbers on both sides of tunnel, minimum of four (4) inches high.

All numbers must be in contrasting colors and easy to read.

Team numbers will be assigned by SAE upon registration according to SAE policy.

8.6.8 Chassis Modification

The snowmobile chassis (bulkhead and tunnel) must be from a stock qualified snowmobile; a snowmobile that was produced in a quantity of at least 300 units.

Teams are not permitted to build their own chassis from the ground up. No modifications may be made to the snowmobile chassis that will reduce structural integrity.

If a team makes modifications to the snowmobile chassis, they will be required to explain to the Technical Inspector what steps (including computer modeling and analysis) were taken to ensure structural integrity and durability.

8.6.9 Rear Hitch Requirement

Both IC and ZE sleds must have a rear hitch capable of a 0.375-inch pin connection (must have clearance for a 3/8-inch pin) providing at least +45 to -45 degrees of yaw rotation about the pin. The hitch must have flap or pitch rotation of +45 to -45 degrees of rotation. Roll degree of freedom is not required. The hitch must be rigid in fore-aft tension and compression and be capable of withstanding 800 pounds draw bar pull force. Pictured below is an example of a snowmobile hitch. These may be fabricated or purchased.

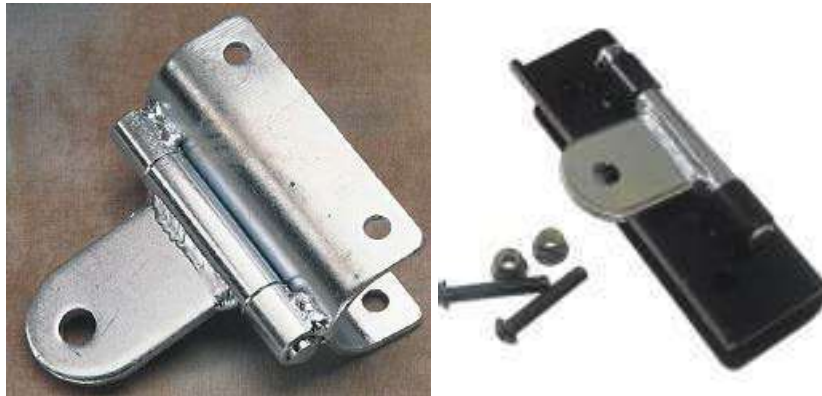

8.7 Ignition and Electrical

8.7.1 Disconnect Tether

All machines must be equipped with a disconnect tether that is operable at all times. Disconnect tethers must be used and attached to the operator whenever the engine is running. The tether must be connected around the operator's wrist (not to his glove or jacket). No alligator clips are allowed. Maximum tether cord length will be five (5) feet. Verification of the tether cord length will be determined at tether cord's fully extended length. The tether switch will be securely mounted in a location on the snowmobile other than on the handlebars. Battery operated electric fuel pumps must be connected to the tether switch. This includes electrically controlled fuel injection systems.

8.7.2 Kill Switch

All snowmobiles must have a handlebar mounted button (on/off) kill switch on the right side within thumb reach (in addition to the tether switch). The kill switch must be programmed so pushing down on the switch will shut down the power to the sled. In other words, up equals "on" and down equals "off."

The reason for this type of kill switch is to provide a common safety feature for judges and organizers

on all the competing sleds. In the event of an emergency, drivers as well as judges and organizers should all know how to disable a snowmobile.

Below is an example of available Kill Switches that meet the requirements:

01-171 Ski-Doo shutdown switch available at
<http://www.mfgsupply.com/m/c/01-171.html?id=UxSI4Vzn>



Note: See EV5.1.7 for additional requirements of shutdown switch.

8.7.3 User Selection Switches
Non-standard user selection switches must be identified.

8.7.4 Battery Box Requirements
Batteries used other than those used for traction must be fully enclosed in a vented, non-conductive box. The purpose of this box is two-fold. First, for unsealed batteries, the box will prevent an acid spill in the event of an accident or “unusual attitude”. And second, for all batteries, the non-conductive box will prevent the positive and negative terminals of the battery from contacting conductive material and/or sparking and starting a fire (in case of an accident).

Note: Venting typically consists of a 1/8” rubber line vented out the bottom of the snowmobile. Battery boxes may be lined with non-conductive material, but the lining must be secure enough to serve its purpose in an accident and/or unusual attitude. Positive terminal must be shielded. Battery box must be securely held in place.

The stock battery box is acceptable if and only if it is modified to meet the above requirements.

There are no exceptions to this requirement. If the technical inspectors are not satisfied that this modification has been made properly, the sled will not compete.

8.7.5 Head, Tail, and Brake Light Requirement
All snowmobiles are required to have functional head, tail, and brake lights. Head lights should provide adequate lighting to allow safe operation in complete darkness at speeds up to 45 miles per hour. Snowmobiles that do not meet these criteria can be penalized and/or ruled ineligible for any events conducted at night.

8.8 Component Deletion
No changes are allowed that would nullify compliance with federal, state, or provincial safety regulations. This includes removal or bypassing emissions components/systems required by the EPA.

8.9 Fire Extinguishers
Each team must have two (2) 0.9 kg (2 lb.) ABC dry chemical/dry powder or 1.75 liters Aqueous Film Forming Foam (AFFF), fire extinguishers. One must be mounted on the rear of the sled and be easily accessible by course workers. This mount must be securely fastened to the vehicle frame and it must resist shaking loose over rough terrain, while allowing the course workers to remove it easily if necessary. If the fire extinguisher falls off the snowmobile during an event a 50-point penalty will be

charged to the team. The second must be brought to technical inspection with mounting accessories; it will be used as a replacement if needed. All fire extinguishers must be equipped with a manufacturer installed dial pressure gauge. The gauge must be readable and indicate a full charge. Extinguishers of larger capacity are acceptable.

Except for the initial inspection, one extinguisher must readily be available in the team's paddock area, and the second must accompany the vehicle wherever the vehicle is moved. Both extinguishers must be presented with the vehicle at Technical Inspection.

Fire extinguishers must be labeled with school name and vehicle number.

ARTICLE 9: CONDUCT OF THE EVENT

9.1 Snowmobile Operating Requirements

9.1.1 Technical Inspection

A Technical inspection of each snowmobile will be performed on Monday March 6, 2017 after it arrives to the competition to determine if it complies with the requirements and restrictions of the rules. If any noncompliance is found, the team will be promptly notified. The team must correct all noncompliance before the snowmobile is permitted to compete in any event. Teams that do not show up with their snowmobile and register on Monday March 6, 2017 will not be allowed to compete the remainder of the week.

Technical inspections will not be performed on Tuesday, March 7, 2017. Any team that does not pass technical inspection on Monday, March 6, 2017, will not compete in the Endurance Run on March 7, 2017 and will forfeit their 100 point no-maintenance bonus (Rule 9.3 below). Check in and technical inspection times for Monday for each team will be posted prior to the competition. Teams must show up at their scheduled time to register and be ready for tech inspection at that time. The penalty for not showing up on time will be 10 points per hour. After 4 hours (40 points) the team will not be eligible to compete in the Endurance Run on March 7, 2017. Again, teams that do not show up with their snowmobile and register on Monday March 6, 2017 will not be allowed to compete the remainder of the week.

Technical Inspections will re-open Wednesday morning. Teams that fail to pass their first Technical Inspections by 4:00 pm Wednesday will be disqualified from the remaining events. Only re-inspections of snowmobiles which had previously passed their first technical inspection will be performed after 4:00pm Wednesday.

It is the responsibility of participating teams to arrive at the competition prepared for the inspection. Teams will fill out and sign their own technical inspection forms indicating that they have checked all items prior to entering the Technical Inspection process.

Decisions of the Chief Technical Inspector concerning compliance or non-compliance with the CSC Rules are final and may not be appealed.

Both a static and a dynamic inspection will be performed on each sled. Sample forms used for the static and dynamic inspections are provided in the appendix.

Passing the Technical inspection does not, in any way; imply that SAE, the CSC organizers, or any individuals acting on their behalf certify that the snowmobile is safe for use. It is the sole responsibility of participating teams to ensure that their snowmobiles are safe for entry in the competition.

9.1.2 Disconnect Tether and Kill Switch

Each snowmobile must be equipped with a disconnect tether and a separate kill switch as described in Rules 8.8.1 and 8.8.2. Twenty-five (25) penalty points will be assessed each time the tether is not properly utilized when the High Voltage is engaged.

9.1.3 Moving Snowmobiles and Test Drives/Practice

When snowmobiles are driven anywhere but in practice areas, snowmobile trails, or roadways they must be driven at a walking pace. During the performance events when the excitement is high, it is particularly important that the snowmobile is driven at a very slow pace. The walking rule will be enforced and point penalties will be assessed for violations of this rule. Test drives may only be made 1) after the sled has passed technical inspections, 2) during scheduled practice periods, and 3) in practice areas designated by the organizers. Teams operating their sled outside the hours and areas designated by the organizers will be disqualified from the competition.

9.1.4 Support Snowmobiles

Team support snowmobiles may be allowed during certain events. The equipment listed in Rules 9.2 to 9.3 must be worn at all times any team member is on any snowmobile that is in motion. The same penalties described in Rule 9.2.4 will be applied to team support snowmobiles. Keweenaw Research Center Test Course guidelines (available upon request) apply to all support snowmobiles.

9.1.5 Warm-Up Stands

Snowmobiles may be placed on warm-up stands before competing in events. However, this warm-up must take place with the snowmobile mounted in a snowmobile stand (you MAY NOT warm up the snowmobile by manually holding the track off of the snow). Twenty-five (25) penalty points will be assessed each time this rule is violated.

The warm-up stand must be designed to catch and retain track, track cleats, traction components and other items that might be thrown by the track. The stand must be no more than six (6) inches from the rear of the tunnel opening and no more than twelve (12) inches from the track. The warm-up stand will be constructed of metal equivalent to 6061T6 aluminum, 1/8 inch thick. Side panels are mandatory and they must extend at least to the center of the rear axle. The sides and back must be secured inside the framework. Vertical coverage must be no more than one (1) inch off the ice and as high as the snowmobile support device. Coverage must be continuous (no lightening holes). A plywood liner is recommended to help absorb impact. The warm-up stand must maintain sufficient height to prevent track coming into contact with ground/ice surface. The stand must be used whenever the rear of a machine is raised to clean out the engine or track, and during warm-up.

Teams may not run their snowmobile engine in the KRC shop/pit area unless directed to do so by an organizer or judge.

A sample illustration of a snowmobile warm-up stand is provided below (courtesy of the International Snowmobile Racing Association).

SNOWMOBILE WARM-UP STAND

sample illustration only (not a design drawing)

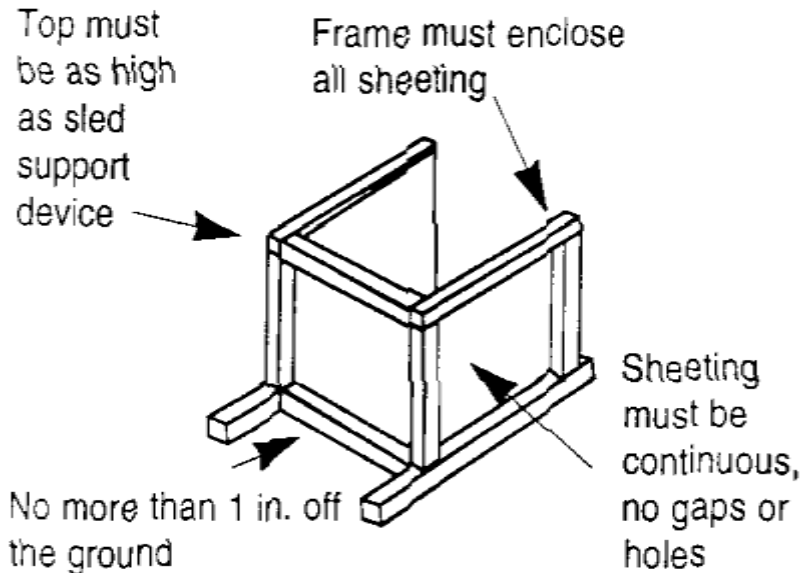

9.2 Driver Protective Equipment

9.2.1 Helmet Requirement

Full coverage helmets that meet Snell 2005 or ECE Regulation 22, Rev. 4 (or newer) are mandatory. Helmet modifications (custom paint, decals, Mohawks, POV cameras, etc.) are not allowed. Helmets not meeting requirements may be impounded for the duration of the competition.

The helmet must be worn and securely fastened by all drivers whenever operating a snowmobile. Eye protection is required. Helmets may be equipped with a chin or full face guard that pivots or flips up for the rider's convenience. These structures are considered integral parts of the helmet and helmets equipped with them must always be used in their downward locked position, or in accordance with the instructions from the manufacturer.

9.2.2 Clothing and Boots

Gloves and clothing, along with boots (above the ankle) are mandatory. The driver's jacket and pants must have of an outer layer that is water and wind resistant, such as nylon, ballistic nylon, Gore-Tex laminates, etc. Cotton pants, blue jeans, and other absorptive fabrics are prohibited. The purpose of this rule is to protect the driver from the cold and moisture that he or she will be exposed to for potentially long times outside during events. The above apparel must be worn by all drivers whenever operating a snowmobile.

Shin/knee guards are mandatory and must be worn on both legs. Shin /knee guards must extend from the top of the boot to above the kneecap, and be constructed of an impenetrable material.

9.2.3 Jacket/Vest

A jacket or vest that conforms to International Snowmobile Racing guidelines must be worn by drivers

during all competition events to protect the upper body. A sample illustration of approved upper body protection is provided below (courtesy of the International Snowmobile Racing Association):

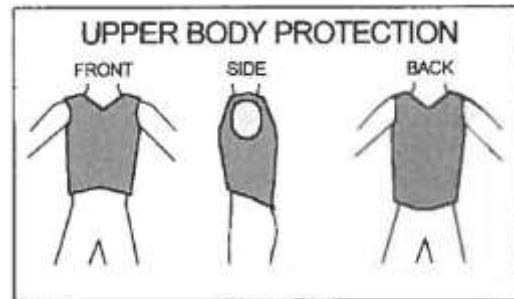

Typical motocross/ATV chest protectors do NOT satisfy this requirement.

9.2.4 Penalties

Twenty-five (25) penalty points will be assessed for each individual not wearing appropriate driver's gear each time the individual is observed to be in violation of the rule by a competition official. Appropriate driver's gear must be worn any time a snowmobile is in motion.

9.3 On Site Modifications (Bonus Points and Penalties)

One hundred (100) bonus points will be awarded to teams who come prepared and do not need to repair or service their sled during the competition. If any parts of the snowmobile burn, fall off, or become missing after the Technical inspection through the completion of the final event, the team will not receive the 100 extra point bonus.

Hoods will be sealed with tamper-proof tape not zip ties. Twenty-five (25) penalty points will be assessed if the hood seal is broken by anyone other than a liaison or a competition official. Once the hood seal is broken, the liaison or competition official will log the reason for the opening and supervise the modification. New hood seals will be installed and the serial number of the new seals will be recorded.

Additional hood openings may be requested to inspect the motor area, however making changes will result in loss of the one hundred (100) point bonus. No changes or modifications to snowmobiles will be allowed after technical inspection except for:

1. Those required to fix compliance issues, in which case the one hundred (100) point bonus is forfeited but no additional penalties will be assessed.
2. Those required to return the snowmobiles to operating condition after a breakdown, in which case the one hundred (100) point bonus is forfeited and additional penalties may apply.
3. Those considered standard maintenance items as described in Rule 9.4, in which case the one hundred (100) point bonus will be forfeited but no additional penalties will be assessed.

If any of the above modifications are to be made, the snowmobile must be serviced in the designated work area. The team may not return the snowmobile to its trailer to perform above maintenance items. Any team that violates this policy will be considered withdrawn from the competition.

In the event that a snowmobile design strategy is "changed" during repairs made after emission testing, the team may continue to compete in events. However, the team will not be eligible to receive any awards for events won after the strategy change.

9.4 Permitted Maintenance Items

The following maintenance items will be allowed throughout the competition without penalty. Teams must notify and obtain permission from competition officials before any permitted maintenance is performed.

Changes in suspension to accommodate rider weight will be allowed without losing the 100-point bonus pertaining all requirements are met in Rule 8.4.4 and 8.5.2.

NOTE: Even though these modifications can be made without penalty, making these modifications will result in automatic loss of the one hundred (100) point No-Maintenance bonus. This includes modifications made at the inspection times listed in section 9.3 above.

- Addition of any fluid – same fluid must be used throughout competition (NOTE: adding significant amounts of coolant will not be considered standard maintenance)
- Track alignment and tension adjustment
- Drive belt/chain tension adjustment
- Headlight bulbs, taillight bulbs, brake light bulb replacement
- Tightening of loose bolts: suspension mounting, suspension front limiter strap, ski saddle, and spindle.
- Lubrication of snowmobile parts.
- Tightening of rear idler wheel bolts and idler adjusting bolt jam nuts.
- Oil/fuel filter replacement
- Changing of the track is **not** in the list of permitted maintenance items. In other words, the average snowmobiler would **not** consider changing of the track a standard maintenance procedure.
- Adding or removing traction studs after the initial technical inspection is **not** permitted.

You will also be penalized for:

- Changing the drive motor (200 pts).
- Replacing pack cells will not be allowed.

NOTE: The intent of this rule is to allow 1000-mile maintenance items to be performed throughout the competition without penalty. Organizers reserve the right to modify and add to this list as conditions demand.

9.5 Drafting Prohibited

Drafting of other snowmobiles will not be allowed during the Fuel Economy & Endurance event. Drafting is defined as following another vehicle closer than three (3) snowmobile lengths at cruising speeds for sustained periods of time. Infractions of this rule may be reported by other competitors or by competition officials. Twenty-five (25) points per occurrence will be deducted for drafting during the Fuel Economy & Endurance event.

9.6 Unsportsmanlike Conduct

Unsportsmanlike conduct will not be tolerated. Any driver, crew member, faculty advisor, or spectator who, by their conduct, detracts from the character of the event, or who abuses, threatens, or uses profane language to an official may be assessed a warning or penalty for unsportsmanlike conduct. A second violation may result in expulsion of the team from the competition. Warnings and penalties may be given by any official and will become record with the approval/concurrence of the organizers.

9.7 Drug and Alcohol Policy

Alcohol, illegal drugs, weapons or other illegal material are prohibited on the event site during the



competition. This rule will be in effect during the entire competition. Any violation of this rule by a team member will cause the expulsion of the entire team. This applies to both team members and faculty advisors. Any use of drugs, or the use of alcohol by an underage individual, will be reported to the local authorities.

Drinking alcoholic beverages anywhere on the Keweenaw Research Center site including buildings, property, or test course is prohibited. There will be a zero-tolerance policy regarding the violation of this rule. Any participant, guest, or advisor violating this rule will cause the immediate disqualification of their team. Volunteers or event staff violating this rule will be dismissed.

There is also a zero-tolerance policy regarding the use of illegal drugs. Any participant, guest, or advisor observed using illegal drugs will cause the immediate disqualification of their team. Volunteers or event staff violating this rule will be dismissed.

9.8 Protests and Problems

Any problems that arise during the competition will be resolved through the organizers and the decision will be final. All protests must be in writing. Protests must be filed within one (1) hour after scores are posted. The decision of the judges and organizers is final.

9.9 Event Appearance and Forfeits

It is the responsibility of the teams to be in the right place at the right time. If a snowmobile is not ready to compete at the scheduled time, then the team forfeits the run of the event and will not be offered a late make-up. The driver for an event will be disqualified if they do not attend the driver meeting for the event.

ARTICLE 10: SCORING

10.1 Overall Score

Overall scores will be determined based on maximum points according to the following schedule:

Zero Emissions Class Event	Minimum Points for Minimum Performance	Maximum Points for Relative Performance in Event
Engineering Design Paper	5	100
Manufacturer's Suggested Retail Price (MSRP)	2.5	50
Oral Presentation	5	100
Weight	0	100
Range	5	100
Draw Bar Pull	5	100
Acceleration + Load Event	2.5	50
Objective Handling and Drivability	2.5	50
Subjective Handling	2.5	50
Cold Start	2.5	50
Static Display	0	50
Objective Noise	3.75	75
Subjective Noise		75
No-Maintenance Bonus		100

10.2 Event Points

The team having the best score in each of the events will be awarded points as described in each event below. Teams finishing behind those leaders will be awarded proportionally fewer points according to a linear scale. No negative points other than as a result of penalties will be awarded.

Points will be granted to teams that meet the minimum requirements of an event. The minimum requirements are outlined in each event that follows.

10.3 Penalties

Penalties will result from violating competition rules, performing prohibited maintenance on snowmobiles at any time after emissions testing, drafting during the Fuel economy/endurance event, or failing to meet competition deadlines.

10.4 Engineering Design Paper

10.4.1 Engineering Design Paper Description

This event requires the team to submit an engineering design paper describing the snowmobile conversion concept, design, and implementation. The paper should explain why modifications were performed and the results of testing and development. The paper must address the durability, practicality, and increased cost of any modifications. Snowmobiles manufactured for 2006 and newer

were required to meet EPA emissions and noise standards. It is expected that teams will modify these sleds to exceed the EPA emission and noise standards. Teams who do not demonstrate in the design paper that they have modified their sled may be disqualified. The addition of and design of components, for example a catalytic converter to reduce exhaust emissions must be explained. An absolute limit of **fifteen (15) pages** will be strictly enforced, except as noted below for papers submitted in alternative accessible formats.

Late engineering design papers will receive ten (10) penalty points for each day that they are late, up to a maximum penalty equal to the team's score for this event. Hand written papers will not be accepted.

Papers must conform to the current two column standard format for SAE technical papers. The format for SAE technical papers is available on-line through the SAE website at:

<http://www.saeleansnowmobile.com>

10.4.2 Engineering Design Paper Scoring

Engineering design paper judges will be a combination of professionals with a technical background in engineering, land management, and other fields related to the snowmobile industry. A sample engineering design paper judging form is located in the Rules Appendix. The weighting of points in each category is noted on the form.

The minimum requirement to receive points in this event will be to submit a paper according to the rules. The average of the judges' score will be the points awarded in this event. In the event that the judges' average score is less than 5 points, the team will receive 5 points.

Penalty points for late design papers will appear in the penalty section of the score sheet and not reduce the team's design paper score.

Regarding Design Changes

It is common that last minute design changes will have to be made due to component failures, late delivery of parts, or technology risks that do not perform as expected. No penalty will be levied if the snowmobile that shows up at the competition is substantially the same snowmobile described in the design paper. Any differences between the snowmobile that is delivered to the competition and the design report must be disclosed to the organizers and revealed at the oral presentation to the presentation reviewers (see section 10.6 below), and to the MSRP judges (see section 10.5 below). If the snowmobile is substantially different than the design report, the organizers may impose penalties or disqualify the snowmobile from the competition.

10.5 Manufacturer's Suggested Retail Price (MSRP)

- 10.5.1 The intent of the Manufacturer's Suggested Retail Price (MSRP) portion of the CSC is for the teams to determine and defend what they believe a reasonable MSRP would be for their sled. The teams are considered the actual manufacturer of the snowmobile they designed and the MSRP they place on the entry is to be for minimum manufacturing quantities of 5000 units/year. Sleds presented at competition are considered prototype units for demonstration of concepts. This exercise is about estimating the final value of the product to the consumer. This is a real exercise that you as graduates will be expected to perform upon entry into professional careers as engineers. The intended purpose of the MSRP is to make a reasonable estimate of what this sled would sell for in today's market. The MSRP in industry is not based on an exact formula, rather an estimate of what the unit can be sold for factoring in manufacturing cost, features offered, and perceived value in the market place. Consequentially any features added to a sled that would improve customer's perceived value must increase the MSRP. No entry with a value less than its equivalent base MSRP will be permitted as it is expected the teams are adding value and features to the snowmobile to improve emissions, fuel economy, and/or reduce emitted

noise. Sled modifications for reasons other than emissions, fuel economy, and noise are permitted and must be included in the MSRP calculation. Teams will be given 20 minutes to present and defend their final MSRP submission to the judges.

10.5.2 Base sled for starting point of MSRP must be 2017 Model Year regardless of the model year of the sled.

10.5.3 MSRP must reflect all factory options included on competition sled (Electric Start, Reverse, etc.).

10.5.4 Electric powered sleds using IC engine chassis should attempt to obtain a reasonable cost of the chassis without engine. If unable to determine reasonable cost of the chassis, teams can reduce initial MSRP by 40% to reflect removal of original power pack (2017 base sled * 60% will be used to calculate base MSRP for electric and diesel powered sleds only).

10.5.5 All MSRPs must include the following additions to meet competition goals:

- Sound treatment
- Studs
- Additional coolers, intercoolers
- Secondary air pumps, plumbing
- Battery pack added to sleds

10.5.6 All base sled modifications must be listed (may or may not add to base MSRP).

Examples include:

- Ski changes
- Suspension changes
- Track substitution
- Battery boxes
- Miscellaneous changes for lights, hand warmers, aesthetics, etc.
- Motor mounting brackets, hardware.

10.5.7 Value of each modification on MSRP must be estimated.

10.5.7.1 Modifications to prototype sled can be considered to add zero value if the items in question would obviously be included in production version.

10.5.7.2 Modifications to prototype sled to reduce weight, increase performance, or otherwise add features/value from base sled must be reflected in an MSRP that is higher than initial value.

10.5.8 All data used to estimate MSRP is to be included in spreadsheet form. This spreadsheet will be available in digital form on saecleansnowmobile.com.

10.5.9 Estimated increase in MSRP must be based on one or more of the following:

- Manufacturing quotes plus 50%
- Wholesale plus 50%
- Retail price for added component, feature or difference between substituted components.
- A justified estimate of manufacturing cost differences between components plus 50% mark up for increased value to customer.

10.5.10 Judging will be conducted by a panel of industry representatives. If the values presented in the MSRP

calculation are not supported with data, the Judges will meet once with the team(s) during the CSC and ask for clarifications or justification. Teams will have the opportunity to adjust the value of their MSRP up or down based on this meeting. One correction of the MSRP will be allowed based on the meeting with the Judges.

10.5.10.1 Teams that do not correct the MSRP to the Judges satisfaction will have the MSRP adjusted upward to what the Judging panel deems a reasonable cost.

10.5.10.2 Teams that are advised during the meeting with Judges that their MSRP is too high but do not adjust the value downward accordingly (or correctly) will have the MSRP value left as presented. The Judging panel will not adjust MSRPs downward, nor assess a penalty, as the higher proposed cost is believed to be a sufficient penalty.

Documentation Required

A spreadsheet tab for documentation will be added. Teams will be required to paste justification documents into the spreadsheet to support cost claims over \$25 dollars (.pdf or .jpeg format)

Part Changes

For part changes from the stock sled, the new price will be calculated by determining production part cost, replacement part cost and determining the more expensive unit. The more expensive price will have 50% premium added to it and this cost will be added to the MSRP. The reason for this change is to end the practice of significantly upgrading sleds with aftermarket parts that list for the same price or in some cases cost less and then request credit off the MSRP. This is in affect improving the customer value without additional cost to the product which is not a real world scenario. Reviewing manufactures websites, the same sled/chassis/engine combination can vary by more than \$1,500.00 when higher performance sleds are ordered with premium suspension components and upgrades.

10.5.11 MSRP Scoring

Scoring for the MSRP will be based on a combination of objective and subjective methods.

The objective part will consist of twenty (20) points to the team with the lowest MSRP after review and correction by the judges. The other team scores will be determined by a linear fit from the lowest to the highest MSRP. The highest MSRP will receive zero points.

In addition, subjective points will be awarded by the judges for the following items associated with determining the MSRP for their sled.

- 10 subjective points for the appropriateness of the choice of the base sled used as their MSRP starting point in the opinion of the judges.
- 10 subjective points for the quality of justifying the reason for their component adds in the opinion of the judges.
- 10 subjective points for the quality of their research in determining price in the opinion of the judges.

MSRP points will also be used to determine the winners of the Most Practical Solution and Best Value awards. Teams that do not submit a complete and accurate MSRP will be ineligible to receive the awards for Most Practical Solution and Best Value.

The minimum requirement for a score in this event is to submit a MSRP according to the rules. In the event that through the above evaluations the team's score is less than 2.5, the minimum score of 2.5 points will be awarded.

Penalties for late submission of the MSRP will appear in the penalty section of the score sheet and not reduce the team's MSRP score.

10.6 Oral Design Presentation

10.6.1 Oral Design Presentation Description

A ten (10) minute oral presentation of the rationale and approach to the conversion is required, followed by a five (5) minute question and answer period. The presentation should state clearly how your modified snowmobile addresses the needs of snowmobilers (performance), environmentalists/land managers/regulatory agencies (noise and emissions), and snowmobile dealers/outfitters (cost, durability, resale value). Your presentation should focus on how your snowmobile will economically and practically reduce the impact that snowmobiles have on the environment. The presentation will be judged on content, format, and delivery. All statements must be backed up with test results and science. This is a marketing delivery that must be based on FACTS.

Each team is required to submit an electronic copy of their oral design presentation to competition organizers at the end of the presentation. Electronic copies may be submitted on a CD or data stick. Teams that fail to provide an electronic copy of their oral presentation will receive zero (0) points for this event. **This requirement will be strictly enforced!**

10.6.2 Oral Design Presentation Scoring

Oral design presentation judges will include snowmobilers, environmentalists, land managers, and engineers. Zero Emissions teams will be judged using a slightly different form appropriate for their competition objective. A sample ZE oral design presentation judging form is located in the Rules Appendix. The average of the judges' scores for each team will equal the points awarded to that team on a 100-point scale weighted as described in the sample judging form.

The minimum performance level for this event is presenting the oral design presentation. If the average of the judges' presentation score is less than 5 points, the team will receive the minimum performance level score of 5 points.

10.7 Zero Emissions Range Test

Zero Emissions snowmobiles will be subjected to a range test. The entries will be run at a speed of 20 mph (or a lower speed set by the organizers based on conditions) on a closed test course until the snowmobile is unable to proceed. There will be no limit on the distance each sled can travel. The team who travels the furthest will receive one hundred (100) points. All other ZE teams that complete the event will receive points based a linear scale where the team that travels the least miles receives 5 points.

The minimum performance level for this event is traveling 500 feet. 5 points will be awarded for traveling 500 feet.

10.7.1 Zero Emissions Draw Bar Pull Test

Zero Emissions snowmobiles will also be subjected to a Draw Bar Pull test. The snowmobile must pull a progressive resistance starting at 4 miles per hour until it can no longer proceed through loss of power or traction. Once the test has started the driver may not bounce the sled in an effort to increase traction. The draw bar pull will be ranked based on an average of three pulls. The maximum average of the pulls will be the highest draw bar pull. Points will be awarded according to a linear scale from lowest draw bar pull (2.5 points) to the highest draw bar pull (50 points).



The minimum performance level for this event is pulling a load for which the team will receive 2.5 points.

10.8 Objective and Subjective Noise Events

10.8.1 Purpose of the Noise Event

The purpose of the objective noise event is to determine the peak A-weighted sound pressure level generated by each snowmobile during a steady state pass-by. In addition, the subjective noise performance (sound quality) of each snowmobile at a bystander location will be evaluated. Zero Emissions snowmobiles will be tested along with IC engine snowmobiles although they have different requirements and design goals.

10.8.2 Noise Event Description

Although a low noise signature for a zero-emissions snowmobile is important, it is not as important as in the IC Class where a high noise reading could result in lost sales. ZE sleds emit less noise and therefore the organizers have decided that the sound pressure created by the sleds will be graded on a relative scale for both the objective noise portion as well as the subjective noise portion of the test.

The snowmobile will be driven by a competition judge according to the published procedure SAE J1161. In addition, the snowmobile must have a functioning speedometer, be capable of operating at a steady-state speed of 15 mph for 150 feet, and be capable of traveling one (1) mile to reach the noise test course while maintaining adequate power to achieve all other requirements.

Every reasonable effort will be made to provide a test site that conforms to SAE J1161 specifications, however this cannot be guaranteed due to changing weather conditions.

A binaural recording system will be placed on one side of the vehicle acceleration lane, also at a distance of 50 feet, for the recording of subjective noise playback files. The side on which the recording system is placed will be chosen by the event staff immediately before the noise event.

The vehicle throttle will be applied smoothly by the operator when the vehicle reaches the start point of the lane. The amount of throttle opening used for the test will be determined by the operator to yield the appropriate speed

The vehicle throttle will be instantaneously and completely released when the vehicle reaches the end point of the lane. From this point, the vehicle will be allowed to coast back down to 10 mph. A portion of this coast-down may be included in the subjective noise recordings.

10.8.3 Subjective Noise Scoring

Data from the above Objective Noise Event will be recorded for playback to a “blind jury”. The jury will consist of attendees to the Clean Snowmobile Challenge. Jury members will be screened to determine their ability to discern the noise playback files. Acceptable jury members will evaluate and grade the playback files. Jury members will not be given the team name of the sound file. Scoring will be based on a linear relationship from the worst to the best. The scale will be 75 points for ZE teams.

10.9 Objective Handling & Drivability Event

10.9.1 Purpose of Objective Handling & Drivability Event

The purpose of this event is to objectively evaluate the agility and maneuverability of each competition snowmobile.

10.9.2 Objective Handling & Drivability Event Description

A student driver from each team will be allowed to complete two (2) consecutive individually timed

laps on a slalom style course (course example below). The fastest lap time will be recorded. No adjustments to the snowmobile will be allowed between laps. A one (1) second penalty will be assessed for each cone, barrel, or bale hit. Five (5) seconds will be assessed if the entire sled does not stop within the designated stopping area.

Zero Emissions sleds will be tested along with IC engine snowmobiles.

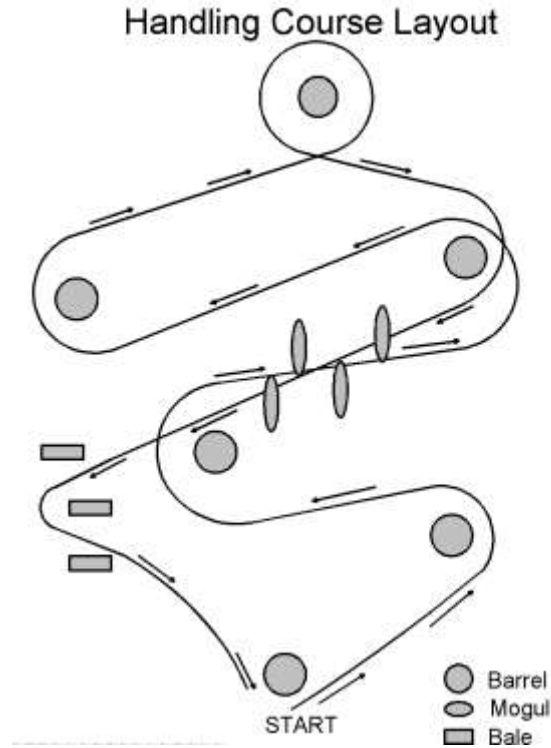

Example course example layout
Not to scale.

10.9.3 Objective Handling & Drivability Rules

The handling event will consist of a course designed to challenge the snowmobiles in the areas concerned with handling. The horsepower of the snowmobile will have very little influence on how well the snowmobile performs in this event. The snowmobiles will be driven by a student team member. This team member must wear the proper safety gear to be eligible for this event as specified earlier.

10.9.4 Objective Handling & Drivability Scoring

The scoring for the event will be based on a linear scale from the fastest time (75 points) to the slowest time which will receive 3.75 points.

The minimum performance level will be to complete one lap of the course.

10.10 Subjective Handling & Drivability Event

10.10.1 Purpose of Subjective Handling & Drivability Event

The purpose of this event is to subjectively evaluate the agility and maneuverability of the competition snowmobile.

10.10.2 Subjective Handling & Drivability Event Description

Professional snowmobile riders will drive each competition snowmobile through a course designed to evaluate handling and drivability. Lap times will not be recorded. Rather, the professional rider will evaluate ride quality based on criteria on the Subjective Handling and Drivability Event Judging Form (see Appendix).

Zero Emissions sleds will be tested along with IC engine snowmobiles.

10.10.3 Subjective Handling & Drivability Rules

The handling event will consist of a course designed to challenge the snowmobiles in the areas concerned with handling and overall drivability. The snowmobiles will be driven by a competition judge.

10.10.4 Subjective Handling & Drivability Scoring

The scoring for the event will be based on the judge’s ranking of each snowmobile according to the Subjective Handling and Drivability Event Judging Form (see Appendix).

Points will be awarded based on the average of the judges’ scores.

The minimum performance level is allowing the judges to evaluate the subjective ride of the sled.

In the event that the judges’ scores average below 2.5, the team will receive 2.5 points.

10.11 Acceleration Plus Load Event

10.11.1 Purpose of the Acceleration Plus Load Event

The purpose of this event is to determine the ability of the snowmobile to pull a heavy load quickly.

10.11.2 Acceleration Plus Load Event Description

Each snowmobile will be driven by a student participant during this event. The snowmobile will be accelerated from a standing stop to the maximum speed that it can achieve in 500 feet. The snowmobile will be timed from start to finish, the lower the time the better. This event will be completed two times and the best time will be the time used for scoring. All drivers must wear the proper safety gear as specified earlier.

Zero Emissions snowmobiles will be tested for acceleration times pulling a load of approximately 500 pounds.

10.11.3 Acceleration Testing Event Scoring

The team with the least time to reach 500 feet pulling another snowmobile which will be riding on top of a plastic recue skid (best of two runs) will receive fifty (50) points.

Any team that passes the event by reaching 500 feet will receive the minimum performance level of 2.5 points.

The remaining sleds will receive additional points on a linear scale from the fastest measured time (50

points) to the slowest time.
$$\text{TeamScore} = 50 + \frac{\left(\frac{T_{\max}}{T_{\text{team}}}\right)^2 - 1}{\left(\frac{T_{\max}}{T_{\min}}\right)^2 - 1} * 50$$

10.12 Cold Start Event

10.12.1 Cold Start Event Description

Snowmobiles will be cold-soaked overnight. Teams will have exactly twenty (20) seconds to start their

snowmobile. The use of ether is not allowed. To pass the event, the snowmobile must start in 20 seconds and then move forward without stalling 100 feet within 120 seconds. If the engine stalls during the 100 feet movement the team will fail.

10.12.2 Cold Start Event Scoring

If a snowmobile does not start within twenty (20) seconds and move 100 feet in 120 seconds, the team will fail the Cold Start event and will receive zero (0) points. Snowmobiles that start within twenty (20) seconds and move 100 feet in 120 seconds will receive fifty (50) points.

Zero Emissions sleds will be tested along with IC engine snowmobiles.

The minimum performance level of the Cold Start Event is starting within 20 seconds.

Teams that start within 20 seconds but fail to move 100 feet in 120 seconds will receive the minimum performance level of 2.5 points.

10.13 Static Display Event/Networking with Industry

10.13.1 Static Display Event Description

Each school must place their snowmobile on display. An area of approximately 8 feet by 10 feet will be provided for your snowmobile and display. The display is intended to serve as a marketing and promotional display that will encourage snowmobilers and outfitters to purchase and use your snowmobile. Teams are encouraged to put up signs, hand out flyers, and use any other marketing techniques to attract attention to your prototype snowmobile.

Zero Emissions sleds will be judged along with IC engine snowmobiles.

10.13.2 Static Display Scoring

This is a mandatory event worth UP TO fifty (50) points. Teams must show up on time and not tear down their display until allowed to do so by the competition organizer. This event will last approximately two (2) hours. Local dealers, snowmobile enthusiasts, and other professionals will tour the displays and judge the display. A sample judging form will be provided prior to the competition. Teams choosing not to attend the static display will receive zero (0) points.

A standardized chart, similar to a new vehicle window sticker, will be required for all snowmobiles. A finalized version of this chart will be provided at the competition. The chart will include basic information about the snowmobile such as chassis make and model, engine size, number of cylinders, 2-stroke or 4-stroke, MSRP, design horsepower, and fuel economy.

10.14 Snowmobile Weight

Each snowmobile will be weighed during technical inspection. The lightest ZE weight sled will receive one hundred (100) points and the heaviest ZE weight sled will receive zero (0) points.

The score for the ZE teams will be based on a linear scale.



ARTICLE 11: AWARDS

11.1 Award Criteria

Note: Awards are contingent upon sponsorship. Past awards include:

Best Zero Emissions:	Presented to team with the highest point value in the ZE category.
Best Design:	Presented to the team receiving the highest total score in the Engineering Design Paper, Oral Design Presentation, and Static Display events
Founder's Trophy:	Trophy awarded to the team recognized by other participants as being the most sportsmanlike.
Cold Start Award:	Presented to teams passing the Cold Start Event
Range Event:	Presented to the team that travels the farthest distance on a single charge.
Draw Bar Pull Award:	Presented to the team that wins the Draw Bar Pull event.
Innovation:	Presented to the team who in the opinion of the organizers has the most innovative solution.
Safety Award:	Presented to the team who in the opinion of the organizer demonstrates the best safe practices.
Most Improved Snowmobile:	Presented to the team who in the opinion of the organizers has improved the most since last year.

Note: Although not guaranteed, some awards will include a cash award dependent on sponsorship. These and other awards will be detailed in the event program available at the on-site competition registration booth.

11.2 Participation Plaque

Each school will receive a plaque commemorating its participation in the competition.

ARTICLE 12: ORGANIZER AUTHORITY

The organizers of the competition reserve the exclusive right to revise the schedule of the competition and/or to interpret the competition rules at any time and in any manner which is, in their sole judgment, required for efficient operation or safety of the competition.

The Keweenaw Research Center (KRC) of Michigan Technological University is the host site for the SAE Clean Snowmobile Challenge. The University has a Safety Manual <http://www.admin.mtu.edu/fm/oshs/pdf/safetymanual.pdf> which applies to all operations at KRC. In addition to wearing safety glasses in the shop areas, safe practices are encouraged and expected at all times. Rules and operating procedures specific to the KRC shop will be reviewed upon arrival.



PART B: ELECTRICAL COMPONENT RULES

ARTICLE EV1 ELECTRIC SYSTEM DEFINITIONS

EV1.1 High-Voltage (HV) and Low-Voltage (LV)

EV1.1.1 Whenever a circuit has a potential difference where the nominal operation voltage is greater than 60V DC or 25V AC RMS it is defined as part of the High Voltage or tractive system.

EV1.1.2 The maximum permitted voltage that may occur between any two electrical connections is 300V.

EV1.1.3 Low voltage is defined as any voltage below 60V DC or 25V AC RMS.

EV1.1.4 Battery segments are sub-divisions of the battery and must respect either a maximum voltage or energy limit. Splitting the battery into its segments is intended to reduce the risks associated with working on the battery.

EV1.2 Grounded Low Voltage and Tractive System

EV1.2.1 The tractive system of the snowmobile is defined as every part that is electrically connected to the motor(s) and batteries.

EV1.2.2 The grounded low voltage (GLV) system of the snowmobile is defined as every electrical part that is not part of the tractive system.

EV1.2.3 The tractive system must be completely isolated from the chassis and any other conductive parts of the snowmobile.

EV1.2.4 The tractive-system is a high voltage system by definition, see EV1.1.1.

EV1.2.5 The GLV system must be a low-voltage-system; see **EV1.1.2**

EV1.2.6 The GLV system must be grounded to the chassis.

EV1.2.7 The tractive and GLV systems must be completely galvanically separated. The border between tractive and GLV system is the galvanic isolation between both systems. Therefore, some components, such as the motor controller, may be part of both systems.

EV1.2.8 All components in the tractive system must be rated for the maximum tractive system voltage.

EV1.2.9 The tractive system motor(s) must be connected to the battery through a motor controller. Bypassing the control system and connecting the tractive system battery directly to the motor(s) is prohibited.

EV1.2.10 The GLV system must be powered up using a specified procedure before it is possible to activate the tractive system; see **EV4.9**. Furthermore, a failure causing the GLV system to shut down must immediately deactivate the tractive system as well.

ARTICLE EV 2 ELECTRIC POWERTRAIN

EV2.1 Motors

Only electrical motors are allowed. Any type of electrical motor is allowed. The number of motors is not limited.

Note: A motor is defined as an electromechanical device which converts electrical energy to mechanical energy.

EV2.2 Accelerator Lever Position Sensor (ALPS)

EV2.2.1 The ALPS must be actuated by a thumb actuated lever on the right handlebar. Lever travel is defined as percent of travel from a fully released position to a fully applied position where 0% is fully released and 100% is fully applied.

EV2.2.2 The lever must return to its original position when not actuated. Two springs must be used to return the lever to the off position and each spring must be capable of returning the lever to the fully released position with the other disconnected.

The springs in the ALPS are not acceptable lever return springs.

EV2.2.3 At least two entirely separate sensors have to be used as ALPSs. The sensors must have different transfer functions, each having a positive slope sense with either different gradients and/or offsets to the other(s).

Note: The intent of this rule is that in a short circuit the ALPSs will only agree at 0% pedal position.

EV2.2.4 If an implausibility occurs between the values of the ALPSs and persists for more than 100msec, the power to the motor(s) must be immediately shut down completely. It is not necessary to completely deactivate the tractive system, the motor controller(s) shutting down the power to the motor(s) is sufficient.

EV2.2.5 Implausibility is defined as a deviation of more than 10% travel between the sensors or other failure as defined in EV2.2.8.

EV2.2.6 If three sensors are used, then in the case of an ALPS failure, any two sensors that agree within 10% travel may be used to define the torque target and the 3rd ALPS may be ignored.

EV2.2.7 Each ALPS must have a separate detachable connector that enables a check of these functions by unplugging it during Electrical Tech Inspection or else an inline switchable break-out box must be made available during Technical Inspection that allows disconnection of each ALPS signal.

EV2.2.8 The ALPS signals must be sent directly to a controller using an analogue signal or via a digital data transmission bus such as CAN or FlexRay. Any failure of the ALPS or ALPS wiring must be detectable by the controller and must be treated like an implausibility, see EV2.2.4.

EV2.2.9 When an analogue signal is used, e.g. from a 5V sensor, the ALPS will be considered to have failed when they achieve an open circuit or short circuit condition which generates a signal outside of the normal operating range, for example $<0.5V$ or $>4.5V$. The circuitry used to evaluate the sensor will use pull down or pull up resistors to ensure that open circuit signals result in a failure being detected.

EV2.2.10 When any kind of digital data transmission is used to transmit the ALPS signal, an FMEA study in the ESF must contain a detailed description of all the potential failure modes that can occur, the strategy that is used to detect these failures and the tests that have been conducted to prove that the detection strategy works. The failures to be considered must include but are not limited to the failure of the ALPS, ALPS signals being out of range, corruption of the message and loss of messages and the associated time outs.

EV2.2.11 Any algorithm or electronic control unit that can manipulate the ALPS signal, for example for vehicle dynamic functions such as traction control, may only lower the total driver requested torque and must never increase it. Thus the drive torque which is requested by the driver may never be exceeded.

EV2.2.12 The current rules are written to only apply to the ALPS, but the integrity of the torque command signal is important in all stages.

EV2.3 Brake System Encoder – BSE

EV2.3.1 A brake system encoder or switch to measure brake lever position or brake system pressure must be fitted to check for plausibility – see EV2.4.

EV2.3.2 The brake system encoder may be used to control regenerative braking.

EV2.3.3 The BSE must have a separate detachable connector that enables detection of error states and the response of the ECU to be checked by unplugging it during Electrical Tech Inspection, otherwise an inline switchable break-out box must be made available during technical inspection that allows disconnection of each BSE signal.

EV2.3.4 The BSE or switch signals must be sent directly to a controller using an analogue signal or via a digital data transmission bus such as CAN or FlexRay. Any failure of the BSE or BSE wiring that persists more than 100 msec must be detectable by the controller and treated like an implausibility such that power to the motor(s) is immediately and completely shut down. It is not necessary to completely deactivate the tractive system, the motor controller(s) shutting down the power to the motor(s) is sufficient.

EV2.3.5 When an analogue signal is used, e.g. from a 5V sensor, the BSE sensors will be considered to have failed when they achieve an open circuit or short circuit condition which generates a signal outside of the normal operating range, for example $<0.5V$ or $>4.5V$. The circuitry used to evaluate the sensor will use pull down or pull up resistors to ensure that open circuit signals result in a failure being detected.

EV2.3.6 When any kind of digital data transmission is used to transmit the BSE signal, an FMEA study in the ESF must contain a detailed description of all the potential failure modes that can occur, the strategy that is used to detect these failures and the tests that have been conducted to prove that the detection strategy works. The failures to be considered must include but are not limited to the failure of the sensor, sensor signals being out of range, corruption of the message and loss of messages and the associated time outs. In all cases a sensor failure must result in power to the motor(s) being immediately shutdown.

EV2.4 ALPS Brake Pedal Plausibility Check

The power to the motors must be immediately shut down completely, if the mechanical brakes are actuated and the ALPS signals more than 25% pedal travel at the same time. This must be demonstrated when the motor controllers are under load.

EV2.4.1 The motor power shut down must remain active until the ALPS signals less than 5% pedal travel, no matter whether the brakes are still actuated or not.

ARTICLE EV 3 TRACTIVE SYSTEM - ENERGY STORAGE

EV3.1 Allowed Tractive System Batteries

EV3.1.1 All types of batteries except molten salt and thermal batteries are allowed. E.g.: Batteries, Super-capacitors, etc. Fuel cells are prohibited.

EV3.1.2 Manufacturer's data sheets showing the rated specification of the battery cell(s) which are used must be provided in the ESF. Battery capacity may not exceed 8kWh at the C1 rate. Battery capacity is calculated using the nominal voltage. Teams must state, as accurately as possible, their battery capacity.

EV3.2 Tractive System Battery Container – General Requirements

EV3.2.1 All batteries which store the tractive system energy must be built into battery segments and must be enclosed in a battery container(s).

EV3.2.2 If spare batteries are to be used then they all must be of the same size, weight and type as those that are replaced. Spare battery packs must be presented at Electrical Tech Inspection.

EV3.2.3 If the battery container(s) is not easily accessible during Electrical Tech Inspection, detailed pictures of the internals taken during assembly must be provided. If the pictures do not adequately depict the battery as determined by the Technical Inspectors, it may be necessary to disassemble the battery to pass Electrical Tech Inspection.

EV3.2.4 Each battery container must be removable from the car while still remaining rules compliant.

EV3.3 Tractive System Battery Container - Electrical Configuration

EV3.3.1 The poles of the tractive system battery stack(s) and/or cells must be insulated against the inside wall of the battery container by a UL recognized or equivalent insulating material rated for the maximum voltage of the tractive system, if the container is made of electrically conductive material. All conductive surfaces on the outside of the container must have a low-resistance connection to the GLV system ground. Special care must be taken to ensure that conductive penetrations, such as mounting hardware, are adequately protected against puncturing the insulating barrier.

EV3.3.2 Every tractive system battery container must contain at least one fuse and at least two battery isolation relays. See **EV3.5**.

EV3.3.3 Maintenance plugs, additional contactors or similar measures must be taken to allow electrical separation of the internal cell segments such that the separated segments contain a maximum static voltage of less than 120 VDC fully charged and a maximum energy of 6MJ. The separation must affect both poles of the segment.

This separation method must be used whenever the tractive system battery containers are opened for maintenance and whenever battery segments are removed from the container.

It must not be physically possible to connect the maintenance plugs in any way other than the design intent configuration.

Maintenance plugs requiring tools to separate the segments will not be accepted.

Maintenance plugs must include a positive locking feature which prevents the plug from unintentionally becoming loose.

Maintenance plugs must be non-conductive on surfaces that do not provide any electrical connections.

- EV3.3.4 Each segment must be electrically insulated by the use of suitable material between the segments in the container and on top of the segment to prevent arc flashes caused by inter segment contact or by parts/tools accidentally falling into the container during maintenance for example. Air is not considered to be a suitable insulation material in this case.
- EV3.3.5 The Battery Isolation Relays (BIRs) and the main fuse must be separated with an electrically insulated and fireproof material to UL94-V0 from the rest of the accumulator. Air is not considered to be a suitable insulation material in this case.
- EV3.3.6 If the HV-connectors of the battery containers can be removed without the use of tools, then a pilot contact/interlock line must be implemented which opens the shutdown circuit (see **EV5.1**) whenever the connector is removed.
- EV3.3.7 Contacting/interconnecting the single cells by soldering in the high current path is prohibited. Soldering wires to cells for the voltage monitoring input of the BMS is allowed since these wires are not part of the high current path.
- EV3.3.8 Every wire used in the battery container, no matter whether it is part of the GLV or tractive system, must be rated to the maximum tractive system voltage.
- EV3.3.9 Each battery container must have a prominent indicator, such as an LED, that will illuminate whenever a voltage greater than 60 VDC is present at the snowmobile side of the BIRs.
- EV3.3.10 The battery voltage indicator (see **EV3.3.9**) must be directly controlled by voltage being present at the connectors using hard-wired electronics. (No software control is permitted). Activating the indicator with the control signal which closes the BIRs is not sufficient.
- EV3.3.11 The battery voltage indicator must always work, e.g. even if the container is removed from the snowmobile and carried around.

EV3.4 Tractive System Battery Container - Mechanical Configuration

- EV3.4.1 All battery containers must be rugged and rigidly mounted to the chassis to prevent the containers from loosening during the dynamic events or possible accidents. If fasteners are used for mounting a battery container, they must comply with T.11
- EV3.4.2 The mounting system must be designed to withstand forces from a 20g deceleration in the horizontal plane and 10g deceleration in the vertical deceleration.
- EV3.4.3 The battery container must be built of mechanically robust material; See **EV3.4.2**.

- EV3.4.4 The container material must be fire resistant according to UL94-V0, FAR25 or equivalent.
- EV3.4.5 The cells and/or segments must be appropriately secured against loosening inside the container and to withstand a 20g deceleration in the horizontal plane and 10g in the vertical plane. Calculations must be included in the ESF to justify your design.
- EV3.4.6 The battery segments contained within the battery must be separated by an UL recognized or equivalent electrically insulating barrier such that the limits of **EV3.3.3** are met. For all lithium based cell chemistries these barriers must also be fire resistant (according to UL94-V0, FAR25 or equivalent) and must further subdivide the battery in 6MJ segments if this is not already met by the separation due to the 120VDC voltage limit.
- Note: The contained energy of a segment is calculated by multiplying the maximum segment voltage with the nominal capacity of the used cell(s).
- EV3.4.7 Holes in the container are only allowed for the wiring-harness, ventilation, cooling or fasteners. These holes must be sealed according to **EV4.6**.
- EV3.4.8 The container must be completely closed at all times when mounted to the snowmobile and also when dismantled from the snowmobile without the need to install extra protective covers. Openings for ventilation should be of a reasonable size, e.g. completely open side pods containing batteries are not allowed.
- EV3.4.9 A sticker with an area of at least 750mm² and a red or black lightning bolt on yellow background or red lightning bolt on white background must be applied on every battery container. The sticker must also contain the text “High Voltage” or something similar if the battery voltage is greater than 40 VDC.
- EV3.4.10 Any battery that may vent an explosive gas must have a ventilation system or pressure relief valve to prevent the vented gas from reaching an explosive concentration.
- EV3.4.11 Every battery container which is completely sealed must have a pressure relief valve to prevent high-pressure in the container.
- EV3.4.12 There must be a battery firewall consisting of a layer of 1.5mm aluminum or equivalent with an insulating layer between the battery and driver. This can be included in the battery enclosure or separate. The insulating layer must be between the battery and battery firewall.
- EV3.5 Battery Isolation Relay(s) (BIR)**
- EV3.5.1 At least two isolation relays must be installed in every tractive system battery container.
- EV3.5.2 The battery isolation relays must open both poles of the tractive system battery.
- EV3.5.3 If these relays are open, no HV may be present outside of the tractive system battery container.
- EV3.5.4 The isolation relays must be of a “normally open” type.
- EV3.5.5 The fuse protecting the battery HV circuit must have a rating lower than the maximum break current of the isolation relays.

EV3.5.6 Battery isolation relays containing mercury are not permitted.

EV3.6 Battery Management System (BMS)

EV3.6.1 Each tractive system battery must be monitored by a battery management system whenever the tractive system is active or the battery is connected to a charger.

EV3.6.2 The BMS must continuously measure cell voltages in order to keep the cells inside the allowed minimum and maximum cell voltages stated in the cell data sheet. If single cells are directly connected in parallel, only one voltage measurement is needed. (See Table 1)

Chemistry	Maximum cells / voltage measurement
PbAcid	6
NiMh	6
Lithium based	1

Table 1 - BMS Voltage Monitoring

EV3.6.3 The BMS must continuously measure the temperatures of critical points of the battery to keep the cells below the allowed maximum cell temperature limit stated in the cell data sheet or below 60°C, whichever is lower.

Cell temperature must be measured at the negative terminal of the respective cell and the sensor used must be in direct contact with either the negative terminal or its busbar. If the sensor is on the busbar, it must be less than 10mm away from the cell terminal.

EV3.6.4 For centralized BMS systems (two or more cells per BMS board), all voltage sense wires to the BMS must be protected by ‘fusible link wires’ or fuses so that any the sense wiring cannot exceed its current carrying capacity in the event of a short circuit. *The fusing must occur in the conductor, wire or pcb trace which is directly connected to the cell tab.*

Any distributed AMS system (one cell measurement per board) where the sense wire connections at the board are <25mm does not need additional fusing if the board is protected from short circuit and the connection to the BMS is also protected. If these conditions are not met, then the positive cell terminal must be protected with a fusible link wire.

Where required, the fusible link wire can form the entire sense wire or a section of the sense wire. If the fusible link wire forms a section of the sense wire, then the gauge of the fusible link wire must be sized appropriately to protect the remaining part of the voltage sense wire from currents above its continuous current rating. If any of these fusible link wires are blown or if the connection to measure the cell voltage is interrupted in any other way, then this must be detected by the BMS and must be reported as a critical voltage problem.

Note 1: If a ‘fusible link wire’ is required and the resistance of the connection from the BMS board to the cell for the voltage measurement is too high, then this can affect the BMS voltage measurement especially during cell balancing and charging, therefore an appropriately large gauge wire must be used.

Note 2: A fusible link wire works such that when an over current event occurs, the conductor within the link is melted while the ensuing flame and spark is contained within the link’s insulation. Specific products can be purchased which perform this function.

EV3.6.5 Any GLV connection to the BMS must be galvanically isolated from the tractive system.

EV3.6.6 The BMS must monitor the temperature of the minimum number of cells in the battery as specified in Table 2 below. The monitored cells must be equally distributed over the battery container(s).

Chemistry	Cells monitored
PbAcid	5%
NiMh	10%
LiIon	30%

Table 2 – BMS Temperature Monitoring

Note: It is acceptable to monitor multiple cells with one sensor if EV3.6.3 is met for all cells sensed by the sensor.

Note: It is strongly recommended to monitor the temperature of all cells.

EV3.6.7 The BMS must shut down the tractive system via opening the BIRs if critical voltage or temperature values according to the cell manufacturer’s datasheet and taking into account the accuracy of the measurement system are detected. If the BMS does perform a shutdown, then a red LED marked BMS must light up on the dash to confirm this.

EV3.7 Grounded Low Voltage System

EV3.7.1 All GLV batteries, i.e. on-board power supplies, must be attached securely to the snowmobile.

EV3.7.2 The hot (ungrounded) terminal must be insulated.

EV3.7.3 GLV Battery packs based on lithium chemistry:

- a. Must have overcurrent protection that trips at or below the maximum specified discharge current of the cells.
- b. Must have a rigid, sturdy and fire retardant casing.
- c. Must be separated from the driver by a firewall.

ARTICLE EV 4 TRACTIVE SYSTEM – GENERAL REQUIREMENTS

EV4.1 Separation of Traction System and Grounded Low Voltage System

EV4.1.1 The layout of electrical devices designed by the team must be documented accurately in the ESF.

EV4.1.2 There must be no connection between the chassis of the vehicle (or any other conductive surface that might be inadvertently touched by a crew member or spectator), and any part of any traction system circuits.

EV4.1.3 Traction system and GLV circuits must be physically segregated such that they are not run through the same conduit or connector, except for interlock circuit connections.

EV4.1.4 GLV circuits must not be present in the battery container except for required purposes. Exceptions include the BIRs, HV DC/DC converters, the BMS and the IMD. The galvanic isolation of any LV wiring within the battery, and where appropriate elsewhere, must be described within the ESF.

EV4.1.5 Where both tractive system circuits and GLV circuits are present within an enclosure, they must be separated by insulating barriers made of moisture resistant, UL recognized or equivalent insulating materials rated for 150 C or higher (e.g. Nomex based electrical insulation), or maintain the following spacing through air, or over a surface (similar to those defined in UL1741):

U < 100 VDC	1 cm (0.4 inch)
100 VDC < U < 200 VDC	2 cm (0.75 inch)
U > 200 VDC	3 cm (1.2 inch)

Table 3 - Enclosure Conductor Spacing

EV4.1.6 Spacing must be clearly defined. Components and cables capable of movement must be positively restrained to maintain spacing.

EV4.1.7 If tractive system circuits and GLV circuits are on the same circuit board they must be on separate, clearly defined areas of the board. Furthermore, the tractive system and GLV areas must be clearly marked on the PCB.

Required spacing are as follows:

Voltage	Over Surface	Thru Air (Cut in board)	Under Coating
0-50 VDC	1.6 mm (1/16")	1.6 mm (1/16")	1 mm
50-150 VDC	6.4 mm (1/4")	3.2 mm (1/8")	2 mm
150-300 VDC	9.5 mm (3/8")	6.4 mm (1/4")	3 mm

Table 4 - PCB Conductor Spacing

EV4.1.8 Teams must be prepared to demonstrate spacing on team-built equipment. Information on this must be included in the electrical system form (**EV11.1**). For inaccessible circuitry, spare boards or appropriate photographs must be available for inspection.

EV4.1.9 All connections to external devices such as laptops from a tractive system component must include galvanic isolation.

EV4.2 Positioning of tractive system parts

EV4.2.1 All parts belonging to the tractive system including cables and wiring must be contained such that they are protected against being damaged in case of a crash or roll-over situation.

EV4.2.2 Tractive system parts should not be mounted in a position where damage will occur from a side or rear impact.

EV4.2.3 In side or front view no part of the tractive system can project below the lower surface of the original tunnel. The goal here is to keep the tractive system above or within the tunnel to protect it from damage caused by hitting the ground.

EV4.3 Tractive System Isolation

EV4.3.1 The driver controls must be referenced to the grounded low voltage system.

- EV4.3.2 There must be a layer of an electrically insulating material between the tractive system and the driver. If the enclosure of the tractive system component is electrically insulating it can be used to meet this requirement.
- EV4.3.3 The insulation material must be fire resistant according to UL94-V0, FAR25 or equivalent.
- EV4.3.4 The insulation material must be puncture and scratch resistant.
- EV4.3.5 **EV4.4** applies if a coated material is used, which is or may become conductive.
- EV4.3.6 HV systems and containers must be protected from moisture in the form of rain or puddles or snow intrusion.
- EV4.3.7 All handle bar controls, indicators, and data acquisition connections must be isolated using optical isolation, transformers, or the equivalent.
- EV4.3.8 Electronic throttle or regenerative braking controls carrying high voltage must be mounted away from the handle bars and dash and actuated through non-conductive or well-grounded mechanical linkages.

EV4.4 Grounding

- EV4.4.1 All electrically conductive parts of the vehicle (e.g. parts made of steel, (anodized) aluminum, any other metal parts, etc.) which are within 100mm of any tractive system or GLV component and driver controls must have a resistance below 300 mOhms (measured with a current of 1A) to GLV system ground.
- EV4.4.2 All parts of the snowmobile which may become electrically conductive (e.g. coated metal parts, carbon fiber parts, etc.) which are within 100mm of any tractive system or GLV component, must have a resistance below 5 ohm to control system ground.
- EV4.4.3 Electrical conductivity of any part may be tested by checking any point which is likely to be conductive. Where no convenient conductive point is available then an area of coating may be removed.

Note: Carbon fiber parts may need special measures such as using copper mesh or similar modifications to keep the ground resistance below 5 ohms.

EV4.5 Tractive System Measuring points (TSMP)

- EV4.5.1 Two tractive system voltage measuring points must be installed directly next to the master switch; see **EV5.2**.
- EV4.5.2 The TSMPs must be protected by a non-conductive housing that can be opened without tools.
- EV4.5.3 The TSMP must be protected from being touched with the bare hand / fingers, even when the housing is opened.
- EV4.5.4 4mm shrouded banana jacks rated to an appropriate voltage level must be used for the TSMPs. See Figure 1 for an example.
- EV4.5.5 The TSMPs must be connected to the positive and negative motor controller/inverter supply lines.

EV4.5.6 Each TSMP must be secured with an appropriately rated current limiting resistor according to the following table. Fusing of the TS measuring points is prohibited.

Maximum TS Voltage	Resistor Value
$U_{max} \leq 200VDC$	5kR
$200VDC \leq U_{max} \leq 300VDC$	10kR

Table 5 - TSMP Resistor Values

EV4.5.7 The TSMPs will be used to check during Electrical Tech Inspection that the tractive system is shut down properly in the given time; see **EV5.1.3**. They are also needed to ensure the isolation of the tractive system of the vehicle for possible rescue operations after an accident or when work on the snowmobile is to be done.

EV4.5.8 Next to the TSMP a GLV system ground measuring point must be installed. This measuring point must be connected to the GLV system ground.

EV4.5.9 A shrouded 4mm banana jack must be used for the GLV ground measuring point; see Figure 1 for an example.



Figure 1 - Shrouded 4mm Banana Jack

EV4.6 HV Insulation, wiring and conduit

EV4.6.1 All parts especially live wires, contacts, etc. of the tractive system; need to be isolated by non-conductive material or covers to be protected from being touched. In order to achieve this, it must not be possible to touch any tractive system connections with a 100 mm long, 6 mm diameter insulated test probe when the tractive system enclosures are in place.

EV4.6.2 Non-conductive covers must prevent inadvertent human contact with any tractive system circuit. This must include crew members working on or around the vehicle. Covers must be secure and adequately rigid. Body panels that must be removed to access other components, etc. are not a substitute for enclosing tractive system connections.

EV4.6.3 Tractive systems and containers must be protected from moisture in the form of rain or puddles or snow intrusion.

Note: A rating of IP65 is recommended for the rain test.

EV4.6.4 Only insulation material that is appropriate for the expected surrounding temperatures may be used and this must have a minimum temperature rating of 90°C. Using only insulating tape or rubber-like paint for insulation is prohibited.

EV4.6.5 All wires and terminals and other conductors used in the tractive system must be sized appropriately for the continuous rating of the fuse which protects them and the wires must be marked with wire gauge, temperature rating and insulation voltage rating. Alternatively, a serial number or a norm printed on the wire is sufficient if this serial number or norm is clearly bound to the wire characteristics for example by a data sheet. The minimum acceptable temperature rating for HV cables is 90°C.

Note: Sizing of conductors for the 'continuous tractive system current' may take account of the RMS or average electrical current that will be used and the anticipated duration of time at maximum electrical current.

EV4.6.6 All tractive system wiring must be done to professional standards with appropriately sized conductors and terminals and with adequate strain relief and protection from loosening due to vibration etc. Conductors and terminals cannot be modified from their original size/shape and must be appropriate for the connection being made.

EV4.6.7 All tractive system wiring that runs outside of electrical enclosures and outside of body panels must be enclosed in separate orange non-conductive conduit. The conduit must be securely anchored at least at each end so that it can withstand a force of 200N without straining the cable, and must be located out of the way of possible snagging or damage.

EV4.6.8 All tractive system wiring that runs outside of electrical enclosures and within the body panels of the snowmobile must either be enclosed in separate orange non-conductive conduit or use an orange shielded cable. Except in the case where the tractive system wiring runs in a fully enclosed container, the conduit or shielded cable must be securely anchored at least at each end so that it can withstand a force of 200N without straining the cable end crimp, and must be located out of the way of possible snagging or damage.

Note: body work is not sufficient to meet this enclosure requirement. Any shielded cable must have the shield grounded.

EV4.6.9 All tractive system connections must be designed so that they use intentional current paths through conductors such as copper or aluminum and should not rely on steel bolts to be the primary conductor. The connections must not include compressible material such as plastic in the stack-up.

EV4.6.10 Tractive system wiring must be shielded against damage by rotating and/or moving parts.

EV4.6.11 If external, un-insulated heat sinks are used, they must be properly grounded to the GLV system ground; see **EV4.4**.

EV4.6.12 Wiring that is not part of the tractive system must not use orange wiring.

EV4.6.13 All electrical connections, including bolts, nuts and other fasteners, in the high current path of the tractive system must be secured from unintentional loosening by the use of positive locking mechanisms that are suitable for high temperatures, for example torque prevailing nuts. For some applications, for example BIRs, it is possible that locking helicoils or similar need to be used. In the case that a locking helicoil or an approved positive locking mechanism is required that cannot easily be inspected at electrical inspection, information about this item must be included in the ESF.

It is also allowed to construct custom locking features that prevent fasteners from coming loose as long as they can be seen to be in place and do not rely on clamping force for the locking feature.

Lock washers and thread locking compounds, e.g. Loctite®, DO NOT meet the positive locking requirement and Nyloc nuts do not meet the temperature requirements.

EV4.7 Tractive System Enclosures

- EV4.7.1 Every housing or enclosure containing parts of the tractive system except motor housings must be labeled with (a) reasonably sized sticker(s) with a red or black lightning bolt on yellow background or red lightning bolt on white background. The sticker must also contain the text “High Voltage” or something similar if the voltage is more than 60 VDC or 25 VAC.
- EV4.7.2 If the housing material is electrically conductive or possibly electrically conductive, it must have a low-resistance connection to GLV system ground; see **EV4.4**.

EV4.8 HV Disconnect (HVD)

- EV4.8.1 It must be possible to disconnect at least one pole of the tractive system battery or disconnect a midpack connection by quickly removing an accessible element, fuse or connector, in case of (a) stuck battery isolation relay(s), for example. Remote activation of the HVD through a long handle, rope or wire is not acceptable.
- EV4.8.2 It must be possible to remove the HVD within 10 seconds from the fully assembled condition. The team must demonstrate this during Electrical Tech Inspection. Being able to quickly disconnect the battery(s) from the rest of the tractive system by its connector(s) will satisfy this rule.
- EV4.8.3 When the HVD is removed, **EV4.6** remains valid, therefore a dummy connector or similar may be needed to restore the system's isolation.
- EV4.8.4 The HV Disconnect must be clearly marked with "HVD".
- EV4.8.5 Tools are not permitted to be used to open the HVD and an interlock must activate the shutdown circuit when the HVD is removed. Hood will be taped shut not zip tied to allow for easier emergency access.

EV4.9 Activating the Tractive System

Snowmobiles in this competition will be operated by judges familiar with the operation of snowmobiles. For this reason, the Zero Emissions snowmobile must be turned on and off like a conventional electric start internal combustions snowmobile.

The ZE snowmobile must have a key operation with OFF, ON, and CRANK positions. In the OFF position the snowmobile will be de-energized (BIR open) and not move when the thumb actuated lever is moved. In the ON position, the snowmobile's GLV systems may be enabled, however the tractive system must remain de-energized until the key is cranked. In the momentary CRANK position, tractive system is enabled. An example of a possible state machine representation of this is shown below.

The shutdown circuit described in EV5.1 will negate all key functions regardless of position and turn all electrical systems off.

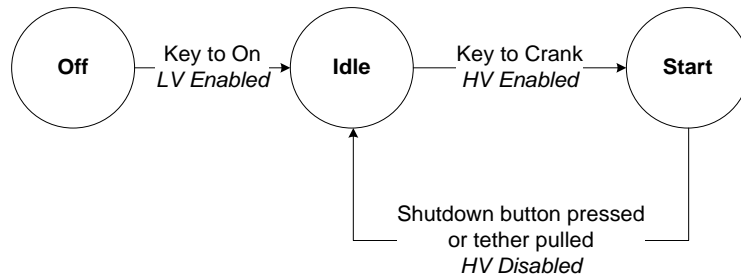

EV4.10 Pre-Charge and Discharge Circuits

EV4.10.1 A circuit that is able to pre-charge the intermediate circuit to at least 90% of the current tractive system battery voltage before closing the second BIR must be implemented. This circuit must be disabled by a de-activated shutdown circuit; see **EV5.1**. Therefore, the pre-charge circuit must not be able to pre-charge the systems if the shutdown circuit is open.

EV4.10.2 Any pre-charge circuitry must be supplied directly from the TSMS.

EV4.10.3 It is allowed to pre-charge the intermediate circuit for a conservatively calculated time before closing the second BIR. A feedback via measuring the current intermediate circuit voltage is not required.

EV4.10.4 If a discharge circuit is needed to meet the requirements of **EV5.1.3**, it must be designed to handle the maximum discharge current for at least 15 seconds. The calculation proving this must be part of the ESF.

EV4.10.5 The discharge circuit must be wired in a way that it is always active whenever the shutdown circuit is open. Furthermore, the discharge circuit must be fail-safe such that it still discharges the intermediate circuit capacitors if the HVD has been opened.

EV4.10.6 Fusing of the precharge and discharge circuits is prohibited.

EV4.11 Vehicle Energized Light

EV4.11.1 The vehicle must include a Vehicle Energized Light that must illuminate when the voltage outside the battery container(s) exceeds 60V DC or 25V AC RMS. The VEL must not perform any other functions.

EV4.11.2 The VEL itself must:

- a. Be directly controlled by the voltage present within the tractive system using hard wired electronics. Software control is not permitted.
- b. Be powered by the GLV system.

EV4.11.3 The vehicle energized light must be green.

EV4.11.4 The vehicle energized light must be labeled Vehicle Energized.

EV4.11.5 The vehicle energized light must be clearly visible even in very bright sunlight.

EV4.12 Ready-To-Drive-Sound

EV4.12.1 The snowmobile must make a characteristic sound, once not continuous, for at least 1 second and a maximum of 3 seconds, when it is ready to drive.



- EV4.12.2 The snowmobile is ready to drive as soon as the motor(s) will respond to the input of the torque control sensor/thumb actuated lever.
- EV4.12.3 The sound level must be a minimum of 80dBA, fast weighing, in a radius of 2m around the snowmobile.
- EV4.12.4 The sound used must be easily recognizable. No animal voices, song parts or sounds that can be interpreted as offensive will be accepted. For example, Sonalert makes many devices which could be used to meet this requirement.
- EV4.12.5 The vehicle must not make other sounds similar to the ready to drive sound.

ARTICLE EV 5 SHUTDOWN CIRCUIT AND SYSTEMS

EV5.1 Shutdown Circuit

- EV5.1.1 The shutdown circuit must directly carry the current driving the battery isolation relays (BIRs).
- EV5.1.2 The shutdown circuit consists of the shutdown switch and the tether in Part A: Rule 8.7.2 and 8.7.1, the tractive system master switch, the insulation monitoring device (IMD), the brake system plausibility device, all required interlocks and the battery management system (BMS).
- EV5.1.3 If the shutdown circuit is opened/interrupted the tractive system must be shut down by opening all battery isolation relay(s) and the voltage in the tractive system must drop to under 60 VDC or 25 VAC RMS in less than five seconds after opening the shutdown circuit. All battery current flow must stop immediately.

An example schematic of the required shutdown circuit, excluding possibly needed interlock circuitry, is shown below. See Figure 2.

Cell balancing when the battery isolation relays are open is not permitted.

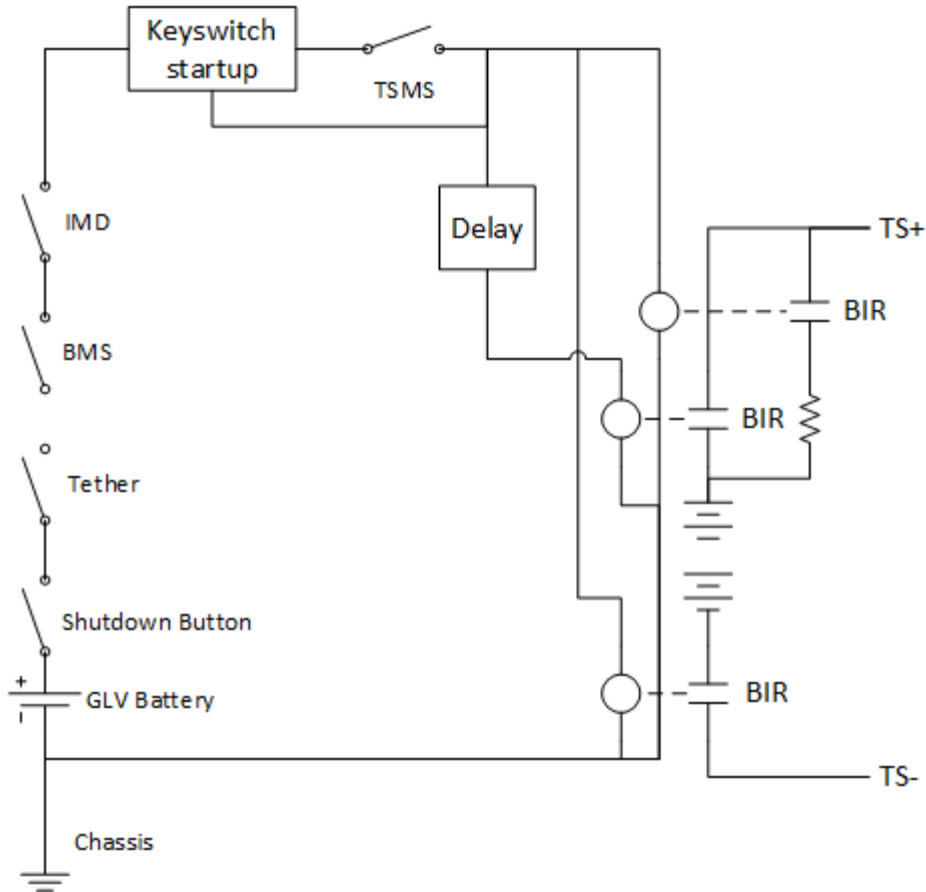

Figure 2 – Example Master Switch and Circuit Configuration

- EV5.1.4 If the shutdown circuit is opened by the BMS, the IMD or the BSPD the tractive system must remain disabled until being manually reset by a person other than the driver. Remote reset, for example via WLAN or use of the shutdown button, tether or TS master switch to reset the BMS, IMD or BSPD is not permitted.
- EV5.1.5 It must not be possible for the driver to re-activate the tractive system while sitting on the snowmobile in case of a BMS, IMD or BSPD fault.

For example: Applying an IMD test resistor between tractive system positive and GLV system ground must deactivate the system. Disconnecting the test resistor must not re-activate the system. The tractive system must remain inactive until it is manually reset.
- EV5.1.6 All circuits that are part of the shutdown circuit must be designed in a way, that in the de-energized / disconnected state they will interrupt the current controlling the BIRs.
- EV5.1.7 If the tractive system is de-activated while driving, the motor(s) must spin free, e.g. no brake torque must be applied to the motor(s).
- EV5.1.8 In order to offer additional protection to the BIRs, it is allowed to use a capacitor to hold the AIRs closed for up to 250ms after removing the current source that keeps them closed, such that the motor controller has some opportunity to reduce the tractive current before the BIRs isolate the accumulator from the rest of the tractive system.

EV5.1.9 It must be possible to demonstrate that all features of the shutdown circuit function correctly. It should be noted that this includes all interlocks.

EV5.1.10 Every system required or able to open the shutdown circuit must have its own, non-programmable power stage to achieve this. The respective power stages must be designed such that a failure cannot result in electrical power being fed back into the electrical shutdown circuit.

EV5.1.11 The shutdown buttons, tether, TSMS and all interlocks must not act through any power stage, but must directly carry the BIR current.

EV5.2 Master Switches

EV5.2.1 Each vehicle must have a Tractive System Master Switch (TSMS):

a. Tractive System Master Switch (TSMS).

EV5.2.2 The TSMS must be located at the rear of the snowmobile.

EV5.2.3 The TSMS must be fitted with a “lockout/tagout” capability to prevent accidental activation of the tractive system. The electrical system officer must ensure that the TSMS is locked in the off position whenever work is done on the vehicle.

EV5.2.4 The TSMS must not be in the high current path. The TSMS must be direct acting, on the shutdown circuit (high voltage relays), i.e. it cannot act through a relay or logic and must be the last switch before the AIRs except for pre-charge circuitry and interlocks.

EV5.2.5 The master switch must be of the rotary type, with a red, removable key, similar to the one shown in the explanatory shutdown circuit and in Figure 3.



Figure 3 - Typical Master Switch

EV5.2.6 The TSMS is not allowed to be easily removable, e.g. mounted onto removable body work.

EV5.2.7 A sticker with a red or black lightning bolt on a yellow background or red lightning bolt on a white background must additionally mark the TSMS.

EV5.3 Insulation Monitoring Device (IMD)

EV5.3.1 Every snowmobile must have an insulation monitoring device (IMD) installed in the tractive system.

EV5.3.2 The IMD must be a Bender A-ISOMETER ® iso-F1 IR155-3203 or -3204 or equivalent IMD approved for automotive use. Equivalency may be approved by the rules committee based on the following criteria: robustness to vibration, operating temperature range, availability of a direct output, a self-test facility and must not be powered by the system which is monitored.

- EV5.3.3 The response value of the IMD needs to be set to 500 ohm / volt, related to the maximum tractive system operation voltage.
- EV5.3.4 In case of an insulation failure or an IMD failure, the IMD must open the BIRs. This must be done without the influence of any logic e.g. a micro-controller. See also **EV5.1.4** and **EV5.1.5** regarding the re-activation of the tractive-system after an insulation fault.
- EV5.3.5 The status of the IMD must be shown to the driver by a red indicator light on the dash that is easily visible even in bright sunlight. This indicator must light up if the IMD detects an insulation failure or if the IMD detects a failure in its own operation e.g. when it loses reference ground.
- EV5.3.6 The IMD indicator light must be clearly marked with the lettering “IMD” or “GFD” (Ground Fault Detector).
- EV5.3.7 The IMD must actively monitor the insulation resistance any time the tractive system is active or the accumulator is charging.

EV5.4 Brake System Plausibility Device (BSPD)

A standalone non-programmable circuit must be used on the car such that when braking hard (without locking the track) and when a positive current is delivered from the motor controller (a current to propel the vehicle forward), the BIRs will be opened. The current limit for triggering the circuit must be set at a level where 5kW of electrical power in the DC circuit is delivered to the motors at the nominal battery voltage. The action of opening the BIRs must occur if the implausibility is persistent for more than 0.5sec. This device must be provided in addition to the plausibility checks which are carried out by the controller which interprets the drivers torque request and delivers torque to the wheels. See also EV5.1.4 and EV5.1.5 regarding the re-activation of the tractive system after triggering of the BSPD.

The team must devise a test to prove this required function during Electrical Tech Inspection. However, it is suggested that it should be possible to achieve this by sending an appropriate signal to the non-programmable circuit that represents the current to achieve 5kW while pressing the brake pedal to a position or with a force that represents hard braking.

EV5.5 Charging Shutdown Circuit

- EV5.5.1 The charging shutdown circuit when charging consists of at least the charger shutdown button, the insulation monitoring device (IMD) and the battery management system (BMS).
- EV5.5.2 If the shutdown circuit is opened by the AMS or the IMD the tractive system must remain disabled until it is manually reset.
- EV5.5.3 The charging shutdown system must comply with EV5.1.1, EV5.1.3, EV5.1.6, EV5.1.8, EV5.1.9 and EV5.1.10.
- EV5.5.4 The charger must include a push type emergency stop button which has a minimum diameter of 25mm and must be clearly labeled.

ARTICLE EV 6 OVERCURRENT PROTECTION

EV6.1 Overcurrent Protection

EV6.1.1 All electrical systems (both tractive system and grounded low voltage system) must have appropriately overcurrent protection.

Note: Fuses are the most commonly used form of overcurrent protection.

- EV6.1.2 The continuous current rating of the overcurrent protection device must not be greater than the continuous current rating of any electrical component, for example wire, bus bar, battery cell or other conductor that it protects.
- EV6.1.3 All overcurrent protection devices must be rated for the highest voltage in the systems they protect. Overcurrent protection devices used for DC must be rated for DC, and must carry a DC rating equal to or greater than the system voltage of the system in which they are used.
- EV6.1.4 All overcurrent protection devices must have an interrupt current rating which is higher than the theoretical short circuit current of the system that it protects.
- EV6.1.5 If multiple parallel batteries, capacitors, strings of batteries, strings of capacitors or conductors are used then each parallel path must have individual overcurrent protection to protect the components. Any conductors, for example wires, busbars, cells, etc. conducting the entire pack current must be appropriately sized for the total current that the individual overcurrent protection devices could transmit or additional overcurrent protection must be used to protect the conductors.
- EV6.1.6 Battery packs with low or non-voltage rated fusible links for cell connections may be used provided that:
- An overcurrent protection device rated at a current three times lower than the sum of the parallel fusible links and complying with EV6.1.2 is connected in series.
 - The battery monitoring system can detect an open fusible link, and will shut down the electrical system by opening HV contactors if a fault is detected.
 - Fusible link current rating is specified in manufacturer's data or suitable test data is provided.
- EV6.1.7 Cells with internal over-current protection may be used without external overcurrent protection if suitably rated.

Note: Most cell internal over-current protection devices are low or non-voltage rated and conditions of **EV6.1.6** will apply.

EV6.1.8 The ESF must include all details of internal and external over current protection including documentation from manufacturer for the particular series and parallel configuration, and string voltage.

ARTICLE EV 7 ELECTRICAL SYSTEM TESTS

EV7.1 Insulation Monitoring Device Test (IMDT)

EV7.1.1 The insulation monitoring device will be tested during Tech Inspection. This is done by connecting a resistor between the TSMP (see **EV4.5**) and several electrically conductive vehicle parts while the tractive system is active, as shown in the example below.

- EV7.1.2 The test is passed if the IMD shuts down the tractive system within 30 seconds at a fault resistance of 250 ohm / volt (50% below the response value).
- EV7.1.3 The IMDT may be repeated at any time during the event. After the snowmobile passes the test for the first time, critical parts of the tractive system will be sealed. The vehicle is not allowed to take part in any dynamic event if any of the seals are broken until the IMDT is successfully passed again at the discretion of the judges.

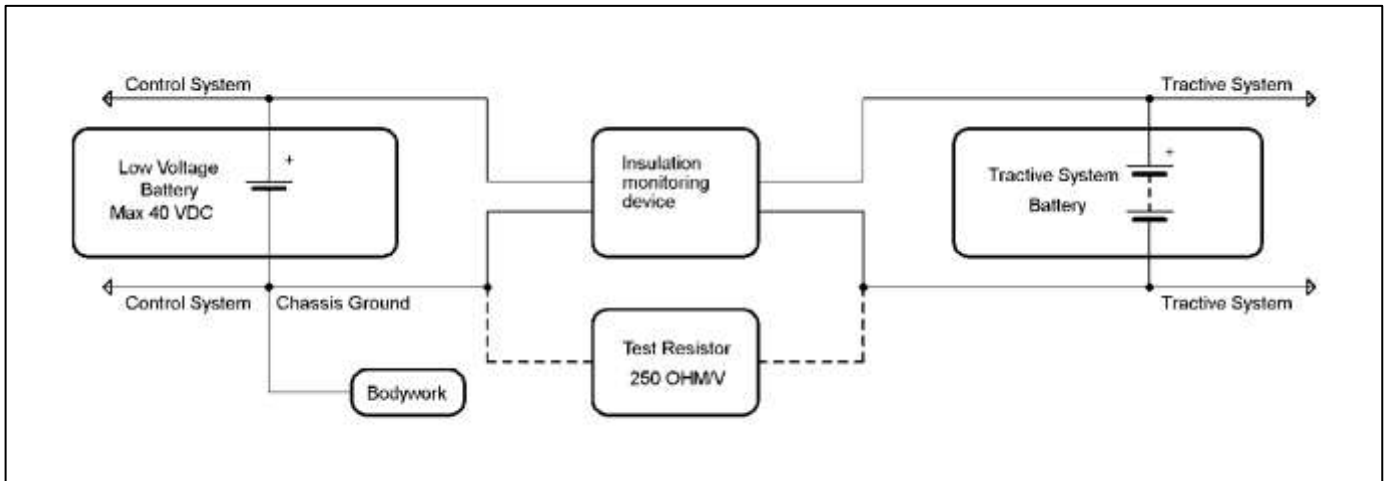

Figure 2 – Insulation Monitoring Device Test

EV7.2 Insulation Measurement Test (IMT)

- EV7.2.1 The insulation resistance between the tractive system and control system ground will be measured during Electrical Tech Inspection. The available measurement voltages are 250 V and 500 V. All snowmobiles with a maximum nominal operation voltage below 500 V will be measured with the next available voltage level. For example, a 175 V system will be measured with 250 V; a 300 V system will be measured with 500 V etc.
- EV7.2.2 To pass the IMT the measured insulation resistance must be at least 500 ohm/volt related to the maximum nominal tractive system operation voltage.

EV7.3 Rain Test

All snowmobiles must pass the Rain Certification Test.

To become Rain Certified, a vehicle must pass a visual inspection that checks that all high and low voltage wiring and components are suitably protected from rain and water thrown up by skis and track. An additional test may require that the vehicle survive a 60 second water spray with all systems energized without tripping the Ground Fault Detector.

The water spray will be directed from the top, front and sides of the vehicle. The spray is intended to simulate rain. A strong stream of water will not be directed at the vehicle.

If a ground fault or other water-related electrical failure occurs during an event, the vehicle will not be permitted to continue the event then underway.



EV7.4 Ready-To-Drive-Sound Test

- EV7.4.1 The sound level will be measured during a static test. Measurements will be made with a free-field microphone placed free from obstructions 1.5m above the ground and 2m from the closest component of the vehicle directed at the vehicle.
- EV7.4.2 This test may be repeated from any location around the vehicle satisfying the conditions of **EV7.4.1**, and must meet the conditions specified in **EV4.12.3**.

ARTICLE EV 8 HIGH VOLTAGE PROCEDURES & TOOLS

EV8.1 Working on Tractive System Battery Containers

- EV8.1.1 If the organizers have provided a “Designated Charging Area”, then opening of or working on battery containers is only allowed in that charging area, see **EV8.2**, and during Electrical Tech Inspection.
- EV8.1.2 Whenever the battery containers are opened the battery segments must be separated by using the maintenance plugs; see **EV3.3.3**.
- EV8.1.3 Whenever the battery or tractive system is being worked on, only appropriate insulated tools may be used.

EV8.2 Charging

- EV8.2.1 If the organizers have provided a “Designated Charging Area”, then charging tractive system batteries is only allowed inside this area.
- EV8.2.2 Batteries may be charged inside the snowmobile.
- EV8.2.3 It is also possible to charge the batteries outside the snowmobile with a removable battery container.
- EV8.2.4 The battery containers or the snowmobile itself, depending on whether the batteries are charged externally or internally, must have a label with the following data during charging: Team name and Safety Responsible phone number(s).
- EV8.2.5 Only chargers presented and sealed at Tech Inspection are allowed. All connections of the charger(s) must be isolated and covered. No open connections are allowed.
- EV8.2.6 No work is allowed on any of the snowmobile’s systems during charging if the batteries are charging inside of or connected to the snowmobile.
- EV8.2.7 No grinding, drilling, etc. is allowed in the charging area.
- EV8.2.8 At least one team member who has knowledge of the charging process must stay with the battery(s) / snowmobile during charging.
- EV8.2.9 Moving of battery cells and/or stack(s) around the event site is only allowed inside a completely closed battery container.
- EV8.2.10 High Voltage wiring in an off board charger does not require conduit; however, it must be a UL listed flexible cable that complies with NEC Article 400; double insulated.



- EV8.2.11 All chargers must either be accredited to a recognized standard e.g. CE or where built by the team they must be built to high standards and conform with all electrical requirements for the vehicle tractive system, for example EV4.1, EV4.3 and EV4.6 as appropriate.
- EV8.2.12 The charger connector must incorporate an interlock such that neither side of the connector becomes live unless correctly connected.
- EV8.2.13 When charging, the IMD and BMS must be live and must be able to turn off the charger in the event that a fault is detected.
- EV8.2.14 HV charging leads must be orange.

EV8.3 Battery Container Hand Cart

- EV8.3.1 In case removable tractive system battery containers are used in order to accommodate charging, a hand cart to transport the batteries must be presented at Tech Inspection.
- EV8.3.2 The hand cart must have a brake such that it can only be released using a dead man's switch, i.e. the brake is always on except when someone releases it by pushing a handle for example.
- EV8.3.3 The brake must be capable to stop the fully loaded battery container hand cart.
- EV8.3.4 The hand cart must be able to carry the load of the battery container(s).
- EV8.3.5 The hand cart(s) must be used whenever the battery container(s) are transported on the event site.
- EV8.3.6 Each team must present the following basic set of tools in good condition during technical inspection:
- Insulated cable shear
 - Insulated screw drivers
 - Multimeter with protected probe tips
 - Insulated tools, if screwed or bolted connections are used in the tractive system
 - Face shield which meets ANSI Z87.1-2003
 - HV insulating gloves which are within test date and protective outer glove
 - Two (2) HV insulating blankets of at least 1 m² or 9 ft² each
 - Safety glasses with side shields for all team members which meet ANSI Z87.1-2003
 - Additional proper tools may be required.

Note: All electrical safety items must be rated for at least the maximum tractive system voltage.

ARTICLE EV 9 ELECTRICAL SYSTEM FORM

EV11.1 Electrical System Form (ESF)

- EV11.1.1 Prior to the event all teams must submit clearly structured documentation of their entire electrical system (including control and tractive system) called the Electrical System Form (ESF).
- EV11.1.2 The ESF must visualize the interconnection of all electric components including the voltage level, the topology, the wiring in the snowmobile and the construction and build of the battery(s).
- EV11.1.3 Teams must present data sheets with rated specifications for all tractive system parts used and show that none of these ratings are exceeded (including wiring components). This includes stress caused by the environment e.g. high temperatures, vibration, etc.



EV11.1.4 A template including the required structure for the ESF will be made available online.

EV11.1.5 The ESF must be submitted as an Adobe PDF file.

EV11.1.6 The minimum allowed font size is 11pts. The font used must be Arial. Small pictures and small schematics should be put inside the text for easy reference, not in the appendix.

EV11.1.7 Data sheets and large schematics should be put in the appendix.

Note: Passing the ESF does not mean that you automatically pass Electrical Tech Inspection with the described items / parts.

ARTICLE T11

T11.1 Fastener Grade Requirements

T11.1.1 All threaded fasteners utilized in the steering, braking, and suspension systems must meet or exceed, SAE Grade 5, Metric Grade 8.8 and/or AN/MS specifications.

ACRONYMS

AC - Alternating Current
BIR - Battery Isolation Relay
BMS - Battery Management System
ANSI - American National Standards Institute
DC - Direct Current
ESF - Electrical System Form
EV - Electrical Vehicle
FMEA - Failure Modes and Effects Analysis
GLV - Grounded Low Voltage
HV - High Voltage
HVD - High Voltage Disconnect
IMD - Insulation Monitoring Device
IMDT - Insulation Monitoring Device Test
IMT - Insulation Measurement Test
LV - Low Voltage
NiMH - Nickel Metal Hydride
PCB - Printed Circuit Board
RMS - Root Mean Squared
TSMP - Tractive System Measuring Point
TSMS - Tractive System Master Switch
UL - Underwriters Laboratory



APPENDIX A

Snowmobile Description Form

The Snowmobile Description Form for the Zero Emissions category is the Electrical System Form (ESF) which is described in Article EV9.

This form can be found online saecleansnowmobile.com.



APPENDIX B

Engineering Design Paper Judging Form - Zero Emissions Sleds Only

University Team Name: _____

Score the following categories, giving each points ranging from 0 (very bad) to the maximum points available for the category (excellent). The maximum points available for each category are listed in parenthesis.
When evaluating the papers, please keep in mind that the papers should be high-quality, technical papers that meet the rigorous standards required for publication in scholarly journals.

_____ **CONTENT – OVERALL PERFORMANCE (10):** Does the paper describe the challenges of the zero-emissions snowmobile? Does the paper describe the strategy the team selected to achieve the required performance? Are adequate technical details given? Are adequate results given?

_____ **CONTENT – RANGE (20):** Does the paper describe the challenges meeting the 10+ mile range requirement? Does the paper describe the strategy team selected to achieve this? Are adequate technical details given? Are adequate results given?

_____ **CONTENT – DRAW BAR PULL (15):** Does the paper describe the challenges of maximizing draw bar pull capabilities of their design? Does the paper describe the strategy team selected to achieve this? Are adequate technical details given? Are adequate results given?

_____ **CONTENT – MISCELLANEOUS (20)** Does the paper describe other features of the snowmobile? How will the modifications affect the cost of the snowmobile? Will the snowmobile be durable? Will the snowmobile be energy efficient? Will the snowmobile be safe to ride? Was rider comfort a major consideration?

_____ **RESULTS/DATA – (10)** Does the paper contain valid numerical data? Are results described based upon testing?

_____ **ORGANIZATION (10)** Is the paper format logical and organized? Did it contain an introduction/overview as well as conclusion/summary? Did the paper conform to the SAE standard format for technical papers?

_____ **USE OF GRAPHICS – TABLES/GRAPHS/PICTURES (10) -** Were graphics used in the paper? Were they clearly explained in the text? Were they legible? Were they effective?

_____ **REFERENCES (5)** Are references cited whenever appropriate? Were the references from high-quality sources?

_____ **TOTAL = ENGINEERING DESIGN PAPER POINTS (100 points maximum)**

COMMENTS:



APPENDIX C Oral Presentation judging form for ZE Sleds

University Team Name: _____

Score the following categories on the basis of 0-12.5 points each according to the following scale (any number or fraction along this scale may be used).

- | | |
|---------------------------------------|--|
| 0 = inadequate or no attempt | 7.5 = above average but still lacking |
| 2.5 = attempted but below expectation | 10 = excellent, meets intent |
| 5 = average or expected | 12.5 = extraordinary, far exceeds expectations |

_____ **CONTENT (SNOWMOBILE OPERATOR PERSPECTIVE):** Does the presentation describe how the design will appeal to scientists working in the North and South Pole areas? Will the snowmobile have sufficient range and power? Is enough detail given about how? How has ergonomics been taken into account?

_____ **CONTENT (SNOWMOBILE DEALER/OUTFITTER PERSPECTIVE):** Does the presentation describe how the design will be serviced in the North and South Pole environment? Is the cost reasonable? Is the design durable and easy to maintain? Does the design allow operation by a novice snowmobiler? Is enough detail given about how these goals are met? Was rider comfort a major consideration?

_____ **CONTENT (ENVIRONMENTAL PERSPECTIVE):** Does the presentation describe how the design will minimize the environmental impacts of the snowmobile? How much? Is the snowmobile quiet enough? How quiet? Is enough detail given about how these goals are met? Are there other factors that make this design more attractive from an environmental perspective?

_____ **CONTENT (TEST RESULTS/SCIENCE):** Are test results given for all of the “claims” made about the modified snowmobile? Is the presentation based on “good science” (as opposed to a slick sale job)? Is data provided to support all conclusions?

_____ **ORGANIZATION:** Were the concepts presented in a logical order progressing from basic concept and showing how the engineering accomplished the concept? Was it clear to the audience what was to be presented and what was coming next? Were distinct introduction and overviews as well as summary and conclusions given?

_____ **VISUAL AIDS:** Were visual aids used? Was the text readable? Were illustrations, graphs, and tables clearly explained? Were the visual aids effective?

_____ **DELIVERY:** Did the presenter speak in a clear voice? Did the presenter show enthusiasm and promote confidence in the technical aspects? Did he/she maintain eye contact?

_____ **QUESTIONS:** Did the answer illustrate that the team fully understood the question? Is there doubt that the team understood the answer? Did the team promote complete confidence in their response to the questions?

_____ **TOTAL = PRESENTATION POINTS (100 points maximum)**

COMMENTS:



APPENDIX D

Handling Event Judging Form for ZE Sleds

University Team Name: _____

Score the following categories, giving each points ranging from 0 (very bad) to the maximum points available for the category (excellent). The maximum points available for each category are listed in parenthesis.

_____ **CORNERING (5):** Does the sled have solid steering? Is handling responsive? Do you have confidence that the sled will go where you point it?

_____ **RIDE (5):** Does the sled impress you as rideable? Could you ride this sled all day and be comfortable? Is sled ride consistent and smooth?

_____ **POWER RESPONSE (7.5):** Is the power response quick and sure? Does speed increase/decrease smoothly? Is there any hesitation to increase speed?

_____ **TRACTION (7.5):** Does the drive train put power to the snow well?

_____ **BRAKING (7.5):** Do the brakes engage properly? Are you confident the brakes will perform in an emergency situation?

_____ **BALANCE (7.5):** Is the sled balanced front to back and side to side? Is the sled nose heavy?

_____ **OVERALL PERFORMANCE (10):** Do all parts of the performance seem to fit together? Are the controls simple and easy to operate? Are the handlebars, seat, and footrest comfortable and well laid out?

_____ **TOTAL HANDLING EVENT POINTS (50 points maximum)**

COMMENTS:

Judge Name _____



APPENDIX E INSPECTION FORMS FOR ZE SLEDS

ZE General Mechanical Technical and Dynamic Tests

Page 1 of 1

University Name				
Team Captain Printed Name		email		
Team Captain Signature		Phone		
Rule Number	Topic	Yes?	No?	Not applicable
	Safety Glasses ok?			
8.9	Fire Extinguishers ok?			
9.1	Operating Requirements			
9.1.5	Warm up stand ok?			
9.2.1	Driver helmet ok?			
9.2.2	Clothing and boots ok?			
9.2.3	Jacket/Vest ok?			
	DYNAMIC TESTS			
8.2	Throttle Return ok?			
8.5.2	Steering ok?			
8.7.1	Disconnect Tether ok?			
8.7.2	Kill Switch ok?			
8.7.3	User Selection switched ok?			
10.8.2	Speedometer ok?			

Inspector Printed Name				
Inspector Signature				



ZE General Technical and Dynamic Tests
Page 1 of 2

University Name				
Team Captain Printed Name		email		
Team Captain Signature		Phone		
Rule Number	Topic	Yes?	No?	Not applicable
EV8.3.6	Insulated cable shear			
	Insulated screw drivers			
	Multimeter with protected probe tips			
	Insulated wrenches, if screwed or bolted connections are used in the tractive system			
	Face shield which meets ANSI Z87.1-2003			
	HV insulating gloves which are within test date and protective outer glove			
	2 HV insulating blankets of at least 1 m ² or 9 ft ² each			
	Safety glasses with side shields for all team members which meet ANSI Z87.1-2003			
8.3.2	Meets brake performance requirement?			
8.3.3	Meets brake control handle requirement?			
8.3.4	Meets brake rotor shield requirement			
8.3.5	Meets rotor contact area requirement?			
8.4	Skis and Ski Suspension			
8.4.1	Meets ski requirements			
8.4.2	Ski and ski suspension modifications okay?			
8.4.4	Ski suspension requirements ok?			
8.5	Track, Track Suspension, and Traction			
8.5.1	Track and track suspension modifications ok?			
8.5.2	Track suspension requirements ok?			
8.5.3	Traction control devices ok?			
8.5.5	Slide runners ok?			
8.5.6	Maximum track lug height ok?			
8.6	Frame and Body			
8.6.1	Rear snow flap ok?			
8.6.2	Foot Stirrups/Pegs ok?			
8.6.3	Seat ok?			
8.6.4	Body modification ok?			



ZE General Technical and Dynamic Tests
Page 1 of 2

8.6.5	Front bumper requirement met?			
8.6.6	Decal space requirement ok?			
8.6.7	Team number correct?			
8.6.8	Chassis Modification (requires explanation and analysis)			
8.6.9	Rear Hitch requirement			
8.7.1	Disconnect tether ok?			
8.7.2	Shutdown Switch ok?			
8.7.3	User Selection Switches including eco/performance ok?			
8.7.4	Battery box requirements met?			
8.7.5	Head, tail, and brake light requirement met?			
8.8	Component deletion requirement met?			

Inspector Printed Name				
Inspector Signature				



APPENDIX F ELECTRICAL INSPECTION FORMS FOR ZE SLEDS

Electrical Technical Inspection Form can be found online under Rules and Important Documents:
saecleansnowmobile.com



APPENDIX G

SAE Technical Standards

The SAE Technical Standards Board (TSB) has made the following SAE Technical Standards available on line, **at no cost**, for use by Collegiate Design teams. Standards are important in all areas of engineering and we urge you to review these documents and to become familiar with their contents and use.

The technical documents listed below include both (1) standards that are identified in the rules and (2) standards that the TSB and the various rules committees believe are valuable references or which may be mentioned in future rule sets.

All Collegiate Design Series teams registered for competitions in North America have access to all the standards listed below - including standards not specific to your competition.

See Clean Snowmobile Challenge Rule A2.20 “Technical Standards Access” for the access procedure.

SAE Technical Standards included in the CDS Rules

Baja SAE

- J586 - Stop Lamps for Use on Motor Vehicles Less Than 2032 mm in Overall Width
- J759 - Lighting Identification Code
- J994 - Alarm - Backup – Electric Laboratory Tests
- J1741 - Discriminating Back-Up Alarm Standard

Clean Snowmobile Challenge

- J192 - Maximum Exterior Sound Level for Snowmobiles
- J1161 - Sound Measurement – Off-Road Self-Propelled Work Machines Operator-Work Cycle

Formula Hybrid

- J1318 - Gaseous Discharge Warning Lamp for Authorized Emergency, Maintenance and Service Vehicles
- J1673 - High Voltage Automotive Wiring Assembly Design

Formula SAE

- SAE 4130 steel is referenced but no specific standard is identified
- SAE Grade 5 bolts are required but no specific standard is identified

Supermileage

- J586 - Stop Lamps for Use on Motor Vehicles Less Than 2032 mm in Overall Width

SAE Technical Standards for Supplemental Use

Standards Relevant to Baja SAE

- J98 – Personal Protection for General Purpose Industrial Machines – Standard
- J183 – Engine Oil Performance and Engine Service Classification - Standard
- J306 – Automotive Gear Lubricant Viscosity Classification - Standard
- J429 – Mechanical and Material Requirements for Externally Threaded Fasteners – Standard
- J512 – Automotive Tube Fittings - Standard
- J517 – Hydraulic Hose - Standard
- J1166 – Sound Measurement – Off-Road Self-Propelled Work Machines Operator-Work Cycle
- J1194 – Rollover Protective Structures (ROPS) for Wheeled Agricultural Tractors
- J1362 – Graphical Symbols for Operator Controls and Displays on Off-Road Self-Propelled Work Machines -



Standard

- J1614 – Wiring Distribution Systems for Construction, Agricultural and Off-Road Work Machines
- J1703 - Motor Vehicle Brake Fluid - Standard
- J2030 – Heavy Duty Electrical Connector Performance Standard
- J2402 – Road Vehicles – Symbols for Controls, Indicators and Tell-Tales - Standard

Standards Relevant to Clean Snowmobile Challenge

- J44 – Service Brake System Performance Requirements – Snowmobiles - Recommended Practice
- J45 – Brake System Test Procedure – Snowmobiles – Recommended Practice
- J68 – Tests for Snowmobile Switching Devices and Components - Recommended Practice
- J89 – Dynamic Cushioning Performance Criteria for Snowmobile Seats - Recommended Practice
- J92 – Snowmobile Throttle Control Systems – Recommended Practice
- J192 – Maximum Exterior Sound Level for Snowmobiles - Recommended Practice
- J288 – Snowmobile Fuel Tanks - Recommended Practice
- J1161 – Operational Sound Level Measurement Procedure for Snowmobiles - Recommended Practice
- J1222 – Speed Control Assurance for Snowmobiles - Recommended Practice
- J1279 – Snowmobile Drive Mechanisms - Recommended Practice
- J1282 – Snowmobile Brake Control Systems - Recommended Practice
- J2567 – Measurement of Exhaust Sound Levels of Stationary Snowmobiles - Recommended Practice

Standards Relevant to Formula SAE

- J183 – Engine Oil Performance and Engine Service Classification - Standard
- J306 – Automotive Gear Lubricant Viscosity Classification - Standard
- J429 – Mechanical and Material Requirements for Externally Threaded Fasteners – Standard
- J452 - General Information – Chemical Compositions, Mechanical and Physical Properties of SAE Aluminum Casting Alloys – Information Report
- J512 – Automotive Tube Fittings - Standard
- J517 – Hydraulic Hose - Standard
- J637 – Automotive V-Belt Drives – Recommended Practice
- J829 – Fuel Tank Filler Cap and Cap Retainer
- J1153 - Hydraulic Cylinders for Motor Vehicle Brakes – Test Procedure
- J1154 – Hydraulic Master Cylinders for Motor Vehicle Brakes - Performance Requirements - Standard
- J1703 - Motor Vehicle Brake Fluid - Standard
- J2045 – Performance Requirements for Fuel System Tubing Assemblies - Standard
- J2053 – Brake Master Cylinder Plastic Reservoir Assembly for Road Vehicles - Standard

Standard Relevant to Formula Hybrid

- J1772 – SAE Electric Vehicle and Plug in Hybrid Conductive Charge Coupler

Standard Relevant to all CDS Competitions

- J1739 – Potential Failure Mode and Effects Analysis in Design (Design FMEA) Potential Failure Mode and Effects Analysis in Manufacturing and Assembly Processes (Process FMEA) and Potential Failure Mode and Effects Analysis for Machinery (Machinery FMEA)